

## ЭЛЕКТРОМОТОРЫ

# 目 录

P6-7	一. 选型步骤
P8	二. 产品图片
P9-12	三. 产品说明
P13	四. 产品结构
P14-27	五. 选型说明
P28-33	六. 电气参数
P34-37	七. 机械特性
P38-53	八. 产品附件
P54-62	九. 电机尺寸
P63-70	杰牌传动产品目录



# CONTENTS

P6-7	Selection Guide
P8	Product Pictures
P9-12	Product Description
P13	Product Structure
P14-27	Selection Description
P28-33	Electrical Parameters
P34-37	Mechanical Properties
P38-53	Product Accessories
P54-62	Motor Dimension
P63-70	JIE Drive Product Catalogue

# 一. 选型步骤

## Selection Guide



1

### 选择杰牌传动产品

例：JD 配减电机、JD-IEC电机、JD-NEMA电机等产品信息。

### Select JIE Drive products

Example: Pick the right model, JD- P motor, JD-IEC motor and JD-NEMA motor.

2

### 输入现用产品品牌

例：杰牌传动、欧美日品牌、中国品牌等信息。

### Enter current product brand

Example: JIE Drive or competitors.

3

### 输入现用产品参数

例：JD 电动机，功率0.12-200kW，极数2、4、6极，能效等级IE3、IE4，电压110-690V，频率50Hz、60Hz、87Hz，防护等级IP55、IP56，绝缘等级F级、H级等型号规格及参数信息。

### Enter current product specifications

Example: JD motor power 0.12-200kW, poles 2, 4, 6, energy efficiency gradeIE3, IE4, voltage 110-690v, frequency 50Hz, 60Hz, 87Hz, protection level IP55, IP56, insulation grade F, H and other specifications.

4

### 生成杰牌产品型号规格

例：JDN90L4-P-D160、JDN90L4-IEC-B3、JDN90L4-IEC-B5-E、JDN90L4-NEMA-145TC等型号规格及参数信息。

### Generate JIE Drive model and specifications

Example: JDN90L4-P-D160、JDN90L4-IEC-B3、JDN90L4-IEC-B5-E、JDN90L4-NEMA-145TC and other models.

5

### 生成杰牌产品2D/3D图

例：JDN90L4-P-D160、JDN90L4-IEC-B3、JDN90L4-IEC-B5-E、JDN90L4-NEMA-145TC等型号2D/3D图信息。

### Generate 2D/3D drawings of JIE Drive products

Example: 2D-3D drawings of JDN90L4-P-D160、JDN90L4-IEC-B3、JDN90L4-IEC-B5-E、JDN90L4-NEMA-145TC and other models.

6

### 确认技术质量标准

例：技术质量标准按杰牌相关标准和双方协议约定的标准执行，质保期自发货之日起18个月或实际使用之日起12个月，以先到为准等信息确认。

### Confirm the technical quality standard

Example: The technical and quality standards shall be implemented according to the relevant standards of JIE Drive and the standards agreed by both parties. The warranty period shall be 12 months after start using products or 18 months after shipment from JIE whichever comes earlier.

7

### 确认交期服务类等信息

例：首次合作按双方协议约定时间交货，提供1+3滚动计划时7天交货；总用量、年用量、月用量、批用量、试用装；售前服务、售中服务、售后服务、预单管理等信息确认。

### Confirm delivery standard

Example: Delivery shall be made according to the time agreed by both parties for the first cooperation; 7 days lead time base on 1+3 rolling plan, including total usage, annual usage, monthly usage, batch usage and sample; confirmation of pre-sales service, in-sales service, after-sales service and pre-order management.

8

### 确认结算价格类等信息

例：30%定金款到后订单生效，余款款到后发货；价格按双方协议约定的价格执行等信息。

### Confirm the settlement price standard

Example: The order comes into effective after 30% deposition received and products will be delivered after balance payment; price shall be subject to agreed upon both parties.

9

### 确认产品订单信息

例：产品名称、型号规格、技术参数、订单数量、产品颜色、包装形式、运输方式、下单时间、交付时间、交付地点、收货单位等信息确认。

### Confirm order information

Example: Confirm product type, model, specification, order quantity, color, packaging, transportation, P.O issue time, delivery time, delivery location, receiving company and other order information.

10

### 确认产品交付等信息

例：样机订单交付、小批订单交付、批量订单交付等信息确认。

### Confirm product delivery information

Example: Confirm prototype delivery, small batch delivery, batch delivery and other delivery information.

## 5. 生成杰牌产品2D/3D图 Generate 2D/3D drawing of JIE products

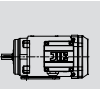
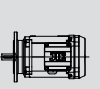

型号	JIE10-4-00
级数	4
功率	15
电压	220/380V
频率	50
额定转速/n <sub>0</sub>	1755
额定电流 I <sub>N</sub>	5A/2.8A
绝缘	F
防护等级	IP55
冷却方式	SI
工作制	E4H
重量	2.0A

尺寸代号		规格代号			性能代号		
名称		字母	1	2	3	名称	
结构尺寸		字母				性能	

外形图	
名称	JIE
型号	JD电动机
名称	JD电动机
名称	JIE10-4-00

型号	JIE10-4-01
级数	4
功率	22
电压	220/380V
频率	50
额定转速/n <sub>0</sub>	1500
额定电流 I <sub>N</sub>	6.5/3.9
绝缘	F
防护等级	IP55
冷却方式	SI
工作制	E4H
重量	2.5

尺寸代号		规格代号			性能代号		
名称		字母	1	2	3	名称	
结构尺寸		字母				性能	

外形图	
名称	JIE
型号	JD电动机
名称	JD电动机
名称	JIE10-4-01

型号	JIE10-4-02
级数	4
功率	22
电压	220/380V
频率	50
额定转速/n <sub>0</sub>	1500
额定电流 I <sub>N</sub>	6.5/3.9
绝缘	F
防护等级	IP55
冷却方式	SI
工作制	E4H
重量	2.5

尺寸代号		规格代号			性能代号		
名称		字母	1	2	3	名称	
结构尺寸		字母				性能	

外形图	
名称	JIE
型号	JD电动机
名称	JD电动机
名称	JIE10-4-02

型号	JIE10-4-03
级数	4
功率	2
电压	220/380V
频率	50
额定转速/n <sub>0</sub>	1755
额定电流 I <sub>N</sub>	5A/2.8A
绝缘	F
防护等级	IP55
冷却方式	SI
工作制	E4H
重量	0.6

尺寸代号		规格代号			性能代号		
名称		字母	1	2	3	名称	
结构尺寸		字母				性能	

外形图	
名称	JIE
型号	JD电动机
名称	JD电动机
名称	JIE10-4-03



## 二. 产品图片 Product Pictures



JD..-E



JD..-P



JD..-BE



其它 Others



## 三. 产品说明

### Product Description

杰牌JD电动机，拥有自主知识产权，产品具有外观美、低噪音、重量轻、快交付和智能化等亮点，包括IEC电机、带制动电机、变频电机、NEMA电机等全系列产品。

杰牌JD电动机，通过完整产品策划与设计 and 全价值链精益生产最优方案实施，推进精益生产、建设智能工厂，实现研产供销服一体化，以满足客户对快速响应的需求。

杰牌JD电动机，遵循模块化和最优化设计理念，全系列产品包括B3、B5、B35、B14等安装型式，同时支持独立风机、制动器、逆止器、编码器、变频器等的模块化组合与集成，产品颜色为RAL7031，并按单包装，可根据客户需要进行个性化的设计与制造。

杰牌为全球好客户做好产品，杰牌智能传动方案提供商！

JD motor with independent intellectual property rights. It has beautiful appearance, featured with low noise and light weight, which is intelligent and fast in delivery. It includes IEC standard motor, Brake motor, Frequency control motor and NEMA standard motor.

JD motor promotes lean production, builds intelligent factories, and realizes the integration of research, production, supply, marketing and service, so as to meet customers' demand for rapid response through complete product planning and design such as "core product-extreme technology, peripheral product-extreme service, external product-extreme experience" and the implementation of the optimal plan of lean production in the whole value chain such as "product planning, design validation, processing test, assembly test, warehouse logistics, sales service, information system, HR, operation plan, strategy planning".

JD motor follows the concept of modular and optimized design. The whole-series product includes B3, B5, B35 and B14 installation types. At the same time, it supports the modular combination and integration of independent fan, brake, backstop, encoder, inverter, with standard painting color RAL7031 & packed based on order. And available for customized base on customer requirement.

JIE is committed to providing great products for great partners across the world, JIE Intelligent Drive Solutions Provider.

## 1. 产品性能特点

### 1. Characteristic Features

#### 输出功率和转矩 Output Power and Torque

选型表中所述的电机功率供选型使用。然而，与所要求的输出转速相对应的输出转矩在应用时是不可缺少的，并且必须要校核检查。

The motor power listed in the selection table is for selection. However, the output torque corresponding to the required output speed is indispensable in application and must be checked.

#### 速度 Speed

标出的电机的输出转速是参考值。实际输出速度与电机的负载和电源条件有关。

The output speed of the motor marked is a reference value. The actual output speed is related to the motor load and power supply conditions.

#### 通风和检查 Ventilation

电机/制动电机安装是在轴向和径向应留有足够的空间，便于空气流通及制动器的维护。请参考相关电机尺寸表中的注释。The installation in the axial and radial should have enough spaces to facilitate the flow of air and maintenance. Please refer to the remarks in the motor dimensions.

#### 制动电机 Brake motor

根据要求杰牌电机可安装集成式机械制动器。请参考该文档的“制动器及其附件”章节。

According to the requirements of JIE motor integrate mechanical brake. Please refer to the JIE brake and its accessories manual.

#### 变频控制 Frequency Control

JDN/JDU电机可以通过变频器控制。

JDN/JDU motor can be controlled by inverter.



## 2. 型号说明 Model Description



<b>1</b> 企业代码 J- 杰牌传动	<b>2</b> 产品代码 D-电动机	<b>3</b> 能效等级 N-3级能效 (IE3) U-2级能效 (IE4)	<b>4</b> 机座号 63-315	<b>5</b> 机座长度 S - 短 M - 中 L - 长 H - 超长
<b>6</b> 极数 2、4、6极	<b>7</b> 电机类型 P-配减电机 IEC-IEC标准电机 NEMA-NEMA电机	<b>8</b> 安装方式 B3-IMB3 B5-IMB5 B14-IMB14 B35-IMB35等	<b>9</b> 接线盒位置 0° 90° 180° 270°	<b>10</b> 电缆接口位置 N、①、②、③

**11** 附件信息 (位置不分先后)  
BE-制动器 TF-温度传感器 TH-恒温器保护装置 PT-温度传感器 U-无通风设计 (无风扇)  
RS-逆止器 Z-高惯量飞轮 C-防雨罩 V-强冷风机 (变频)  
E-编码器 STH-电加热带 RI-加强绝缘 DH-冷凝排水孔 2WE-后出轴

<b>1</b> Enterprise code J-JIE Drive	<b>2</b> Product code D-Motor	<b>3</b> Energy efficiency index N-level3 (IE3) U-level2 (IE4)	<b>4</b> Frame sizes 63-315	<b>5</b> Core length S - Short M - Medium L - Long H - High
<b>6</b> Poles 2、4、6 poles	<b>7</b> Mounting positions P-Reduction motor IEC-IEC motor NEMA-NEMA motor	<b>8</b> Installation method B3-IMB3 B5-IMB5 B14-IMB14 B35-IMB35etc	<b>9</b> Terminal box position 0° 90° 180° 270°	<b>10</b> Cable interface position N、①、②、③

**11** Attachment information (No sequence)  
BE- Brake TF-Temperature TH-Thermostat protection device  
PT-Temperature sensors U-Non-ventilated(No fan) RS-Backstop  
Z-Additional flywheel C-Protection cowl V-Forced cooling fan  
E-Encoder STH-Electric heating RI-Reinforced insulation  
DH-Condensation drain holes 2WE-Rear shaft of the motor

### 3. 电机型号说明 Model Description

#### 电动机能效 Energy efficiency

表1/Table 1

型号/Type	描述/Description
JDN63S-315H	IEC60034-IE3, 3级能效(Energy efficiency level 3)GB18613-2020
JDU63S-315H	IEC60034-IE4, 2级能效(Energy efficiency level 2)GB18613-2020

#### 安装形式 Mounting arrangement

表2/Table 2

型号/Type	描述/Description
B3	IEC地脚安装电机(功率等级设计不符合IEC标准时需描述中心高) IEC ground mounting motor (when the power level design does't meet the IEC standard should describe the height of the center)
B5	IEC法兰安装电机光孔连接 IEC flange mounting motor light hole connection
B14	IEC法兰安装电机螺纹孔连接 IEC flange mounting motor threaded hole connection
B35	IEC法兰(光孔连接)地脚安装(功率等级设计不符合IEC标准时需描述中心高) IEC flange (light hole connection) to the foot installation(when the power level design does't meet the IEC standard should describe the height of the center)

注: 具体尺寸请参照电机外形尺寸表 Note: Please refer to the motor size table for specific dimensions

#### 制动器 Brake

表3/Table 3

型号/Type	描述/Description
BE	制动器/Brake
HR	手柄释放/Handle release
HF	螺钉释放/Screw release

#### 温度传感器/温度检测 Temperature sensor / temperature detection

表4/Table 4

型号/Type	描述/Description
TF	温度传感器(PTC热敏电阻保护) Temperature sensor (PTC thermistor protection)
TH	恒温保护装置(双金属片开关) Thermostat protection device (bimetal switch)
PT	1个或3个PT100温度传感器 One or three PT100 sensors

#### 编码器 Encoder

表5/Table 5

型号/Type	描述/Description
E	RS422(带反相信号)5VDC供电 RS422 (With reverse signal) 5VDC powered by RS422(带反相信号)10-30VDC供电 RS422 (With reverse signal) 10-30VDC powered by 推挽HTL(带反相信号)10-30VDC供电 HTL (With reverse signal) 10-30VDC powered by 推挽HTL(无反相信号)10-30VDC供电 HTL (No reverse signal) 10-30VDC powered by NPN集电极开路输出 10-30VDC供电 NPN 10-30VDC powered by

注: 客户若有其他需求, 请与杰牌公司联系 Note: If you have any other requirements, please contact JIE



## 冷却 Cooling

表6/Table 6

型号/Type	描述/Description
V	强制冷风扇/Forced cooling fan
U	无通风设计(无风扇)/Non-ventilated(No fan)

注: JD电动机无其他冷却方式要求时, 冷却方式为自扇冷式(IC411)。  
 Note: If there is no special cooling requirement, type of cooling is fan-cooled(IC411)

## 其他选项 Other options

表7/Table 7

型号/Type	描述/Description
RI	加强绝缘/Reinforced insulation
STH	电加热带/Electric Heating
DH	冷凝排水孔/Condensation drain holes
RS	逆止器/Backstop
2WE	电机(制动电机)后出轴/Rear shaft of the motor
C	防雨罩/Protection cowl
Z	高惯量飞轮/Additional flywheel

## 安装方式说明 Mounting arrangement instructions

JD电动机的结构及安装型式IM B3、IM B6、IM B7、IM B8、IM B14、IM B35、IM B34、IM B65、IM B75、IM B85、IM V1、IM V15、IM V5、IM V6和IM V36的规定制造。The mounting types of motor are made follow IM B3、IM B6、IM B7、IM B8、IM B14、IM B35、IM B34、IM B65、IM B75、IM B85、IM V1、IM V15、IM V5、IM V6 and M V36 .



图1 / Chart 1

JD 电动机接线盒及电缆接口位置, 电动机地脚安装结构没有90° 位置。用户下订单时, 请说明电机接线盒及电缆接口位置。  
 JD motor terminal box and cable interface position, the motor feet installation doesn't have the 90° position. Please specify the location of motor terminal box and cable interface .

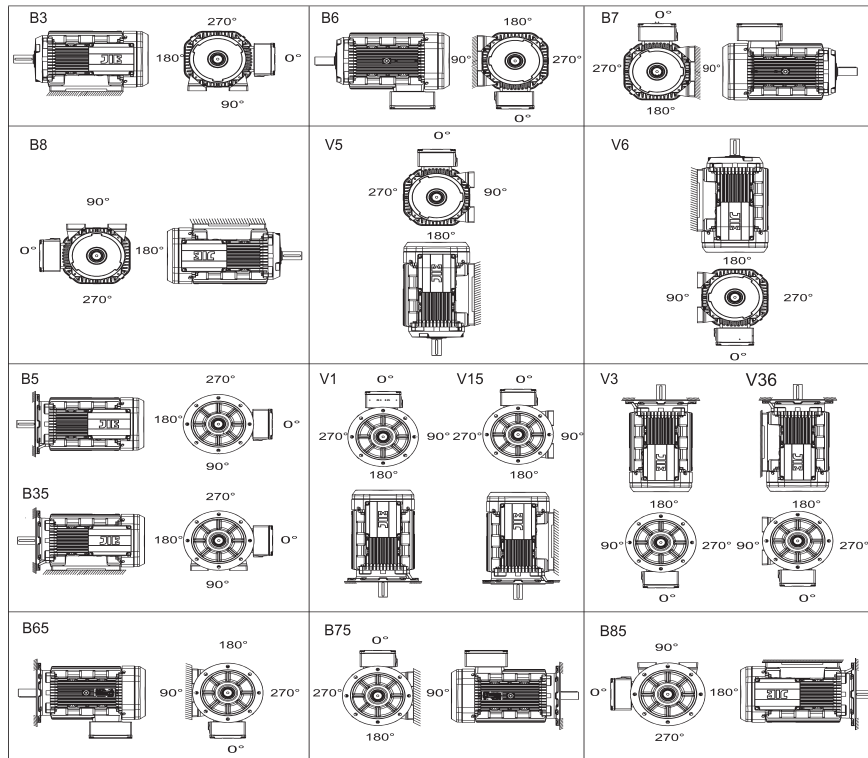

图2 / Chart 2

## 四. 产品结构 Product Structure

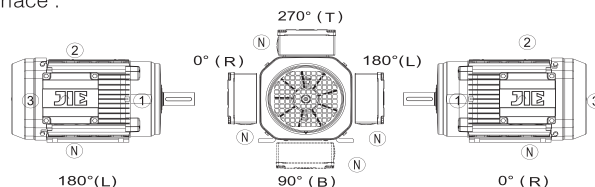

图3 / Chart 3

- |                            |                              |                           |                        |                              |
|----------------------------|------------------------------|---------------------------|------------------------|------------------------------|
| 1. 油封/Oil seal             | 8. 出线孔盖/Hole cover of outley | 15. 螺栓/Bolt               | 22. 螺栓/Bolt            | 29. 轴用挡圈/Shaft with a collar |
| 2. A端盖/A endshield         | 9. 接线盒座/Terminal box base    | 16. 接线盒盖/Terminal box lid | 23. 后端盖/Rear endshield | 30. 风扇/Fan                   |
| 3. 孔用挡圈/Circlips for holes | 10. 螺钉/Screw                 | 17. 螺钉/Screw              | 24. 油封/Oil seal        | 31. 轴承/Bearing               |
| 4. 定子/Stator               | 11. 接地牌/Ground card          | 18. 接线排/Wiring row        | 25. 风罩/Fan cowl        | 32. 转子/Rotor                 |
| 5. 接线板/Terminal board      | 12. 垫圈/Washer                | 19. 螺栓/Bolt               | 26. 密封塞/Sealing plug   | 33. 键/Key                    |
| 6. 螺钉/Screw                | 13. 螺栓/Bolt                  | 20. 密封垫/Gasket            | 27. 地脚/Feet            | 34. 轴承/Bearing               |
| 7. 密封胶垫/Gasket             | 14. 密封胶垫/Gasket              | 21. 波形弹簧/Wave washer      | 28. 螺钉/Screw           | 35. 轴用挡圈/Shaft with a collar |

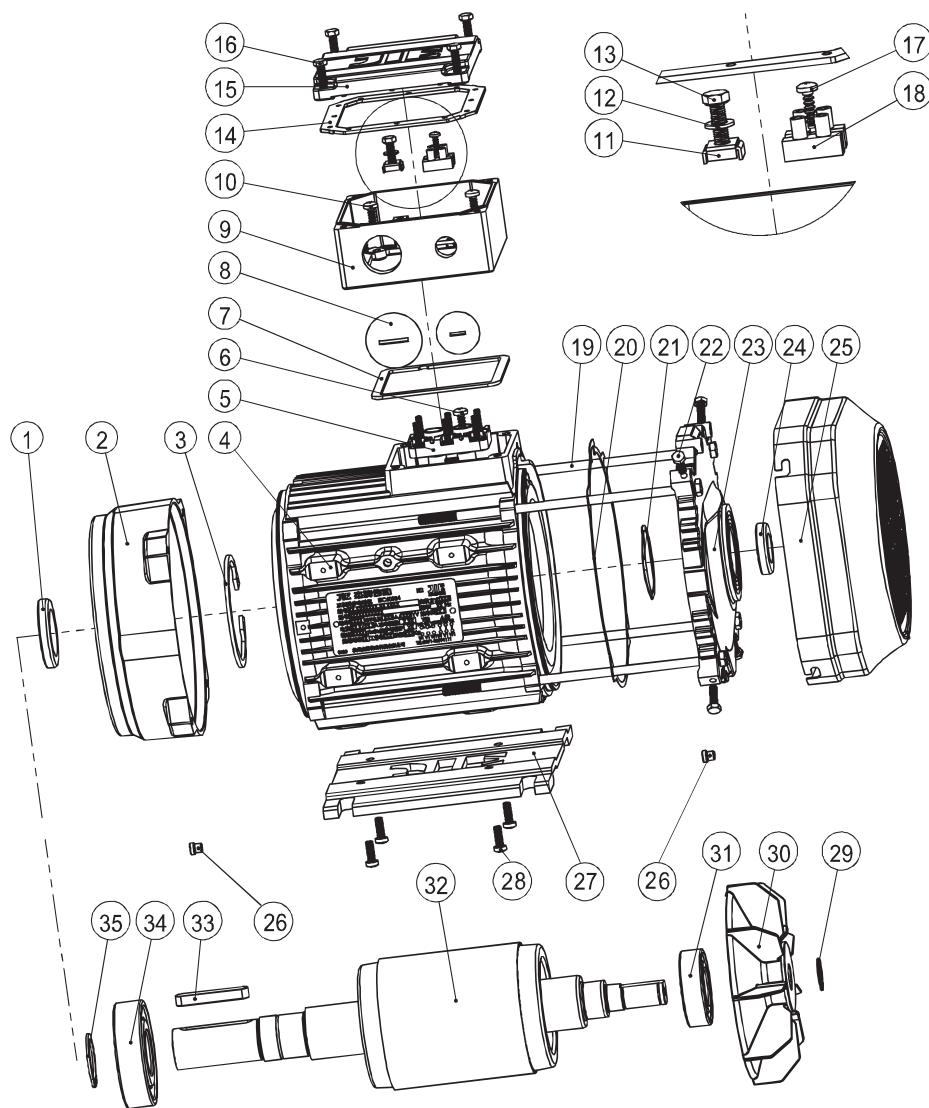

## 五. 选型说明

### Selection Description

#### 1. 杰牌传动JD产品选型表

<b>使用工况:</b>	
应用行业:	设备名称:
环境温度:	环境湿度:
海拔高度:	使用场地: <input type="checkbox"/> 室内 <input type="checkbox"/> 室外
起停频率:	运行时间:
负载时间: <input type="checkbox"/> 15% <input type="checkbox"/> 25% <input type="checkbox"/> 40% <input type="checkbox"/> 60% <input type="checkbox"/> 75% <input type="checkbox"/> 100%	
现用品牌:	现用型号:
存在问题:	需改进项:

<b>产品信息:</b>	
包装附件类:	
包装材质: <input type="checkbox"/> 纸箱 <input type="checkbox"/> 木箱	箱贴唛头: <input type="checkbox"/> 中文 <input type="checkbox"/> 英文
相关资料: <input type="checkbox"/> 合格证 <input type="checkbox"/> 出厂检验报告 <input type="checkbox"/> 中文使用说明书 <input type="checkbox"/> 英文使用说明书	
附件清单: <input type="checkbox"/> 空心轴编码器ES <input type="checkbox"/> 实心轴编码器EV <input type="checkbox"/> 热敏电阻TF <input type="checkbox"/> 热保护开关TH <input type="checkbox"/> 铂热电阻PT100 <input type="checkbox"/> 防雨罩C <input type="checkbox"/> 电加热带STH	
外观标识类:	
油漆颜色: <input type="checkbox"/> JMR-01 <input type="checkbox"/> JMG-01 <input type="checkbox"/> JGB-01 <input type="checkbox"/> RAL2002 <input type="checkbox"/> RAL5015 <input type="checkbox"/> RAL9003 <input type="checkbox"/> RAL7045 <input type="checkbox"/> RAL7031	
铭牌要求: <input type="checkbox"/> 中文 <input type="checkbox"/> 英文	防腐要求: <input type="checkbox"/> 标准 <input type="checkbox"/> JS1 <input type="checkbox"/> JS2 <input type="checkbox"/> JS3 <input type="checkbox"/> JS4
安装尺寸类	
电机类型: <input type="checkbox"/> 普通 <input type="checkbox"/> 变频 <input type="checkbox"/> 制动 <input type="checkbox"/> 变频制动	安装形式: <input type="checkbox"/> B3 <input type="checkbox"/> B5 <input type="checkbox"/> B35 <input type="checkbox"/> B14
接线盒角度: <input type="checkbox"/> 0° <input type="checkbox"/> 90° <input type="checkbox"/> 180° <input type="checkbox"/> 270°	出线位置: <input type="checkbox"/> N <input type="checkbox"/> 1 <input type="checkbox"/> 2 <input type="checkbox"/> 3 (见附图)
性能指标类:	
额定功率: kW	极数: <input type="checkbox"/> 2 <input type="checkbox"/> 4 <input type="checkbox"/> 6 <input type="checkbox"/> 8
额定电压: <input type="checkbox"/> 220/380V <input type="checkbox"/> 380/660V	电机频率: <input type="checkbox"/> 50Hz <input type="checkbox"/> 60Hz <input type="checkbox"/> 87Hz
绝缘等级: <input type="checkbox"/> F <input type="checkbox"/> H	防护等级: <input type="checkbox"/> IP54 <input type="checkbox"/> IP55 <input type="checkbox"/> IP56
工作制: <input type="checkbox"/> S1 <input type="checkbox"/> S3-40% <input type="checkbox"/> S3-75%	冷却方式: <input type="checkbox"/> IC410 <input type="checkbox"/> IC411 <input type="checkbox"/> IC416
能效等级: <input type="checkbox"/> 3级 (IE3) <input type="checkbox"/> 2级 (IE4)	旋转方向: <input type="checkbox"/> 顺时针 <input type="checkbox"/> 逆时针
风机电压: <input type="checkbox"/> DC 24V <input type="checkbox"/> AC 220V (1~) <input type="checkbox"/> AC 380V (3~) <input type="checkbox"/> AC 220/380V (3~)	
风机频率: <input type="checkbox"/> 50Hz <input type="checkbox"/> 60Hz	
制动电压: <input type="checkbox"/> DC 24V <input type="checkbox"/> AC 220V <input type="checkbox"/> AC 380V	
释放装置: <input type="checkbox"/> 手柄释放HR <input type="checkbox"/> 螺钉释放HF <input type="checkbox"/> 无 制动器响应: <input type="checkbox"/> 普通 <input type="checkbox"/> 快速	
释放装置与接线盒角度 (从轴伸端看顺时针): <input type="checkbox"/> 0° <input type="checkbox"/> 90° <input type="checkbox"/> 180° <input type="checkbox"/> 270° (见附图)	
产品型号: _____	



**定制信息:**

包装附件类:

外观标识类:

安装尺寸类:

性能指标类:

售后服务类:

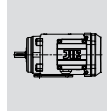
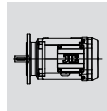

**服务信息:**

售前服务:

培训咨询: 选型培训 应用培训 使用维护

设计选型: 参与设计 设计校核 产品选型

需求确认: 工况确认 产品确认 服务确认

售中服务: 驻厂全检 过程抽检 出厂检验

售后服务: 安装调试 检测维护 备品备件

**商务信息:**

运输方式:

交付地点:

交付时间:

订单数量:

结算价格:

**附图:**

接线盒角度:

出线位置:



图4



## Selection Table of JIE JD Products

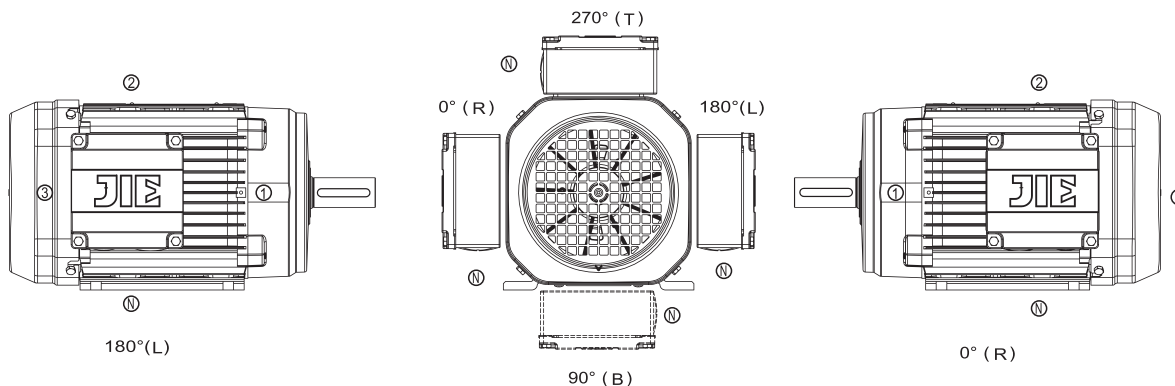

<b>Conditions of use:</b>	
Application industry:	Equipment name:
Ambient temperature:	Ambient humidity:
Altitude:	Site of use: <input type="checkbox"/> indoor <input type="checkbox"/> outdoor
Start-stop frequency:	Running time:
Load time: <input type="checkbox"/> 15% <input type="checkbox"/> 25% <input type="checkbox"/> 40% <input type="checkbox"/> 60% <input type="checkbox"/> 75% <input type="checkbox"/> 100%	
Current brand:	Current model:
Existing problem:	Items needing improvement:
<b>Product information:</b>	
Packaging:	
Packaging material: <input type="checkbox"/> Carton <input type="checkbox"/> Wooden case <input type="checkbox"/> Carton + Wooden case	Case mark: <input type="checkbox"/> Chinese <input type="checkbox"/> English
Relevant data: <input type="checkbox"/> Certificate of conformity <input type="checkbox"/> Ex-factory inspection report <input type="checkbox"/> Chinese operating instruction <input type="checkbox"/> English operating instruction	
List of accessories: <input type="checkbox"/> Backstop <input type="checkbox"/> Hollow shaft encoder ES <input type="checkbox"/> Solid shaft encoder EV <input type="checkbox"/> Thermistor TF <input type="checkbox"/> Thermal protection switch TH <input type="checkbox"/> Platinum thermal resistance PT100 <input type="checkbox"/> Rain cover C <input type="checkbox"/> Electric heating tape STH	
Appearance:	
Paint color: <input type="checkbox"/> JMR-01 <input type="checkbox"/> JMG-01 <input type="checkbox"/> JGB-01 <input type="checkbox"/> RAL2002 <input type="checkbox"/> RAL5015 <input type="checkbox"/> RAL9003 <input type="checkbox"/> RAL7045 <input type="checkbox"/> RAL7031	
Nameplate requirement: <input type="checkbox"/> Chinese <input type="checkbox"/> English Anti-corrosive grade: <input type="checkbox"/> Standard <input type="checkbox"/> JS1 <input type="checkbox"/> JS2 <input type="checkbox"/> JS3 <input type="checkbox"/> JS4	
Installation:	
Motor Type: <input type="checkbox"/> Normal <input type="checkbox"/> Frequency <input type="checkbox"/> Braking <input type="checkbox"/> Frequency & braking Type of installation: <input type="checkbox"/> B3 <input type="checkbox"/> B5 <input type="checkbox"/> B35 <input type="checkbox"/> B14	
Terminal box angle: <input type="checkbox"/> 0° <input type="checkbox"/> 90° <input type="checkbox"/> 180° <input type="checkbox"/> 270° (see attached figure) Cable entry: <input type="checkbox"/> N <input type="checkbox"/> 1 <input type="checkbox"/> 2 <input type="checkbox"/> 3 (see attached figure)	
Performance:	
Rated power: kW	Pole number: <input type="checkbox"/> 2 <input type="checkbox"/> 4 <input type="checkbox"/> 6 <input type="checkbox"/> 8
Rated voltage: <input type="checkbox"/> 220/380V <input type="checkbox"/> 380/660V	Motor frequency: <input type="checkbox"/> 50Hz <input type="checkbox"/> 60Hz <input type="checkbox"/> 87Hz
Insulation grade: <input type="checkbox"/> F <input type="checkbox"/> H	Protection grade: <input type="checkbox"/> IP54 <input type="checkbox"/> IP55 <input type="checkbox"/> IP56
Working system: <input type="checkbox"/> S1 <input type="checkbox"/> S3-40% <input type="checkbox"/> S3-75%	Cooling mode: <input type="checkbox"/> IC410 <input type="checkbox"/> IC411 <input type="checkbox"/> IC416
Energy efficiency class: <input type="checkbox"/> IE3 <input type="checkbox"/> IE4	
Fan voltage: <input type="checkbox"/> DC 24V <input type="checkbox"/> AC 220V (1~) <input type="checkbox"/> AC 380V (3~) <input type="checkbox"/> AC 220/380V (3~)	
Fan frequency: <input type="checkbox"/> 50Hz <input type="checkbox"/> 60Hz	
Braking voltage: <input type="checkbox"/> DC 24V <input type="checkbox"/> AC 220V <input type="checkbox"/> AC 380V	
Release device: <input type="checkbox"/> Handle release HR <input type="checkbox"/> Screw release HF <input type="checkbox"/> None brake response: <input type="checkbox"/> Ordinary <input type="checkbox"/> Fast	
Angle between release device and terminal box (clockwise from the end of shaft extension): <input type="checkbox"/> 0° <input type="checkbox"/> 90° <input type="checkbox"/> 180° <input type="checkbox"/> 270° (see attached figure)	
Product model: _____	

Customized information:

Packing category:

Appearance class:

Installation dimension:

Performance indicators:

After-sales service:

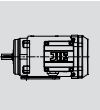
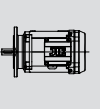

Service information:

Pre-sales service:

Training consulting:  Type selection training  Application training  Use and maintenance

Design selection:  Participate in design  Design verification  Product selection

Demand confirmation:  Working condition confirmation  Product confirmation  Service confirmation

In-sales service:  On-site full inspection  Process sampling  Ex-factory inspection

After-sales service:  Installation and commissioning  Testing and maintenance  Spare parts

Business information:

Transportation:

Delivery place:

Delivery time:

Order quantity:

Settlement price:

Attached figure:

Terminal box angle:

Out of line position:

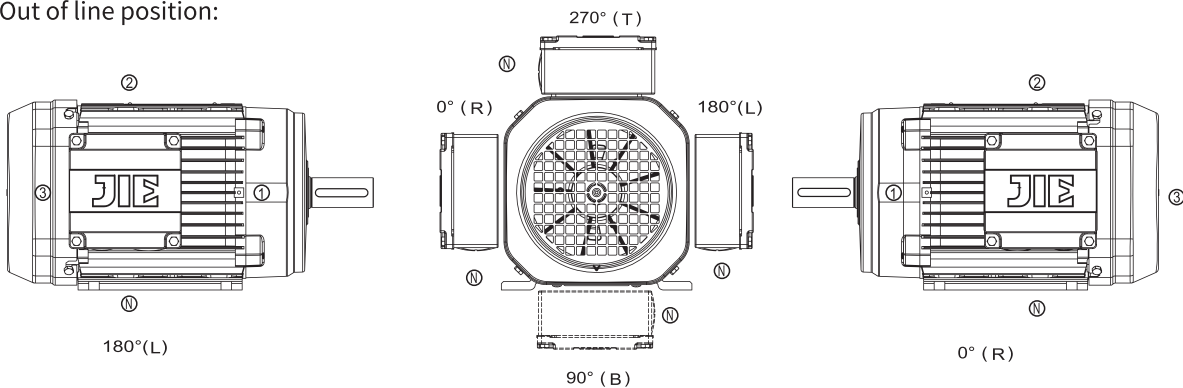

Chart 4

## 2. 标准与规定

### Standards and Regulations

#### 电机执行标准 Execution standard

- IEC 60034-1 EN 60034-1  
旋转电机定额及性能/Rotating motor quota and performance
- IEC 60034-2-1 EN 60034-1  
旋转电机通过试验测定旋转电机损耗和效率的标准方法  
Standard Method for Determining Rotor Motor Loss and Efficiency by Rotating Motor
- IEC 60034-9 EN 60034-9  
旋转电机噪音限制/Rotating motor noise limits
- IEC60034-14 EN60034-14  
旋转电机振动标准/Rotating motor vibration standard
- IEC 60034-30  
旋转电机效率等级IE3、IE4等级/Rotary motor efficiency pole IE3、IE4  
EN60529、IEC60034-5、EN60034-5
- IP防护等级/ Degree of IP protection

#### 额定数据 Rated data

三相异步电动机的具体数据/Three-phase asynchronous motor specific data

- 规格/Type
- 额定功率/Rated Output
- 负载持续率/Cyclic Duration Factor
- 额定转速/Rated Speed
- 额定电流/Rated Current
- 额定电压/Rated Voltage
- 功率因数/Cos/Power Factor
- 防护等级/Degree of Protection
- 绝缘等级/Insulation Class
- 效率/Efficiency

以上数据在电机铭牌上标出。根据IEC 60034 ( EN 60034 ) 此铭牌数据是针对环境温度最高在40°C、海拔最高在1000米的情况。

The above datas are marked on the motor nameplate. According to IEC 60034 (EN 60034) this nameplate data is for ambient temperatures up to 40°C and elevations up to 1000 m above sea level.

JD电动机铭牌  
JD motors nameplate

举例  
Example

	名称	_____		安装方式	_____
	型号	_____		频率	Hz
+86-571 82991111	编号	_____		效率%	_____
	功率	kW	电压 $\Delta$ / YV	功率因数	_____
	电流	A	绝缘等级	防护等级IP	_____
	转速	r/min	工作制	重量	kg
	制动电压	V	重量	kg	_____
	制动扭矩	Nm	重量	kg	_____

杭州杰牌传动科技有限公司

图5 / Chart 5

## 偏差 Deviation

根据IEC60034 ( EN 60034 ) 在额定电压时 ( 或额定电压范围内 ) 电机性能的偏差如下:  
According the IEC60034(EN60034) with the rated voltage(or range of rated voltage),the deviation of motor's performance is as:

表8 /Table 8

序号 serial number	电气性能名称 Electrical performance name	容差 Tolerance
1	效率 Efficiency 额定功率在132kW及以下 The rated power is 132kW and lower 额定功率在132kW以上 The rated power is over 132kW	-0.15 (1- $\eta$ ) -0.10 (1- $\eta$ )
2	功率因数, $\cos\Phi$ Power factor $\cos\Phi$	$-(1-\cos\Phi)/6$ 最小绝对值0.02 最大绝对值0.07
3	转差率 $P_N < 1kW$ Slip $P_N \geq 1kW$	$\pm 30\%$ $\pm 20\%$
4	堵转转矩倍数 Locked rotor torque	保证值的 -15% Protection value
5	最大转矩倍数 Maximum torque	保证值的 -10% Protection value
6	堵转电流倍数 Locked rotor current multiple	保证值的 +20% Protection value
7	转动惯量 Mass moment of inertia	$\pm 10\%$

## 偏差A, 偏差B Deviation A, Deviation B

偏差A和B区描述的允许偏差范围是在频率和电压允许偏离各自额定点的范围内, 下图描述了这个范围。原点“0”被视为频率和电压各自的额定点。

The bounds of allowable deviation characterized in the Deviations A zones and B zones are the bounds when frequencies and voltages are allowed to deviate from their respective fixed points, please refer to the following figure. The origin "0" is regarded as the respective fixed point of frequency and voltage



图6/Chart 6

在偏差A范围内, 电机必须能在连续工作制 ( S1 ) 下输出额定扭矩。其它特性值和温升与额定频率、电压下的值稍有偏差。

在偏差B范围内, 电机在非连续工作制下能输出额定扭矩。温升及额定参数的偏离比A高时应尽量避免电机经常在偏差B范围内运行。

In the range of deviation A, the motor must output rated torque in the continuous working (S1). Other characteristic value and temperature rise with the rated frequency, the voltage value have the slight deviation. The motor can output the rated torque in the discontinuous working in the range of B. when the deviation of temperature rises and the rated parameter is higher than A, the motor should avoid to run in the range of deviation B.

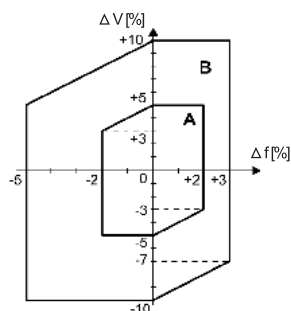
## 欠电压 Undervoltage

如果出现欠电压或使用不适当的电机电缆, 功率、转矩和转速参数可能达不到样本中所列的数值, 特别是在电机启动时, 启动电流需要额定电流的数倍。

If there is an undervoltage or improper voltage, the motor power, torque and rotational speed parameters may not reach the values listed in the sample book, especially when the motor is started, the starting current is several times than the rated current.

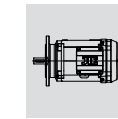

### 3. 电气性能

## Electrical Performance



适用于变频控制 Apply to converter fed control.

JD电动机（制动）采用高性能绕组作为标准配置，全部可用于变频器控制。

JD series AC (brake) motors adapt high performance winding as standard configuration for the frequency conversion control.



#### 频率 Frequency

根据需要杰牌的JD电动机设计为供电频率50Hz或60Hz。标准设计为50Hz，在电机参数表中的技术数据是基于供电频率50Hz。

有些特殊的JDN和JDU电动机可以在50Hz和60Hz供电系统下运行。不同电气规则的地区可通用一种电机。

不同国家关于最低效率等级的规范可以用一种合理方法实现。

对于这类特殊电机，请您联系杰牌公司。

According to the requirement, JIE motors are designed for 50Hz or 60Hz. 50Hz is the standard design. In the motor parameter table, some special JDN and JDU motor can work on the 50Hz and 60Hz.

One type motor can be used universally in the area with different electricity regulation.

The different countries' different minimum efficiency grade regulations can be realized with an ideal method. About these special motors, please contact to JIE.

#### 电机电压 Motor voltage

标准电机和能效电机均满足额定电压范围：220V-690V。

额定功率在3kW及以下的电机通常按照以下设计：

- 额定电压220V $\Delta$ /380VY 50Hz。Y接出厂。

额定功率在4kW及以上的电机通常按照以下设计：

- 额定电压380V $\Delta$ /660VY 50Hz。 $\Delta$ 接出厂。

注：电机电压使用范围在标准电压的 $\pm 5\%$ 以内。（如220V $\Delta$ /380VY 50Hz可在210V~230V $\Delta$ /360V~400VY 50Hz范围内正常使用）

Standard motor and high efficiency motor can match rated voltage range : 220V-690V

The motor of 3kW and below will be designed as following:

- The rated voltage 220V $\Delta$ /380VY 50Hz Y to leave the factory.

The motor of 4kW and above will be designed as following:

- Rated voltage 380V $\Delta$ /660VY 50Hz  $\Delta$  to leave the factory.

Remark: the application range of motor voltage is within the  $\pm 5\%$ . (for example, 220V $\Delta$ /380VY 50Hz can be used within 210V-230V $\Delta$ /360V-400VY 50Hz)

#### 强冷风机电压 Forced cooling fan

表9 / Table 9

电源类型 Power type	电源电压 Power voltage	电源频率 Power frequency
三相 Three phase	380VAC	50Hz
	380VAC	60Hz
单相 Single phase	220VAC	50Hz
	220VAC	60Hz

• 风机为宽电压使用，在电压波动 $\pm 5\%$ 的范围（即电压在50Hz 基频下220-240 $\Delta$ /380-420Y）内，其风量应不低于表中的规定值的5%，其测试方法按GB1236 测试。

• 风机的外壳防护等级为IP54。

• 风机绝缘等级为F级，其绕组温升不得超过80K（电阻法）。

• 风机的驱动电机绕组对地应承受历时1分钟的耐压试验而不击穿，其试验频率为50Hz，实际波形为正弦波，电压有效值为1000V+2U<sub>N</sub>(V)。（U<sub>N</sub>：风机的额定电压）

• 风机的驱动电机绕组对机壳的绝缘电阻在常温下不低于20M $\Omega$ 。

When the fan work on the wide voltage, the voltage fluctuates within  $\pm 5\%$  (220–240V/380–420V, 50Hz). The air flow is not lower than 5% of the data in the table, and the test follow GB1236.

The IP grade of fan is IP54

The insulation grade is F, the winding temperature can't rise over 80K (electric-resistivity method)

The coil of fan motor will not be broke down withstanding 1 minute breakdown test to the ground, the test frequency is 50Hz, the actual waveform is sine wave, and the voltage effective value is 1000 2UN (V), (UN: the rated voltage of fan)

Insulation resistance of the fan motor winding to the cover will not be lower than 20M in the normal temperature

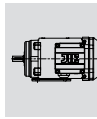
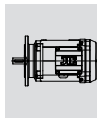

## 制动器参数 Brake data

表10 /Table 10

制动器电压: Brake voltage	电机功率4kW 以下: 单相AC220V The motor power is lower than 4kW: 220V 1~
	电机功率4kW 以上 (包括4kW): 单相AC380V The motor power is over 4kW (include 4 kw): 380V 1~
整流方式: Mode of rectification	制动电压为110VAC–260VAC 时为全波整流 Full wave rectification when braking voltage is 110VAC–260VAC
	制动电压为261VAC–575VAC 时为半波整流 Half wave rectification when the brake voltage is 261VAC–575VAC
释放装置: Release mode	HR (手柄释放) HF (螺钉释放) HR(handle release)HF(screws release)

## 绝缘耐热性能 Insulation resistance

根据 (IEC 60034–1) 划分的温升等级

所有三相异步 (制动) 电机是以绝缘等级155 (F) 级作为设计标准, 根据要求也可采用绝缘等级180 (H) 级。下表列出了符合IEC62114和IEC60034–1 (EN60034–1) 要求的温升。

According to the IEC60034–1 temperature rise classification.

All three phase asynchronous motors are based on the insulation level 155(F) as the design standard, and can also be compliant to requirements of the insulation class 180(H). The following table lists the temperature rise in accordance with the requirements of IEC62114 and IEC60034.

表12 /Table 12

绝缘等级 Insulation class		温升限值[K] Temperature limit [K]
新/New	旧/Old	
155	F	105K
180	H	125K

## 功率减小 Power Reduction

电机的额定功率 $P_N$ 取决于环境温度和安装海拔高度。铭牌上的额定功率对应海拔1000m以下和40 °C以内的环境温度。如果环境温度更高或安装海拔高度更高, 电机额定功率将相应减小,

可用下列公式修正:

The rated power of the motor P depends on the ambient temperature and installation elevation. The normal rated power on the nameplate is measured with condition below 1000m above sea level and the temperature less than 40 degrees. If the ambient temperature is higher or the installation elevation is higher, the motor rated power will be reduced accordingly.

$$P_{Nred} = P_N \times f_T \times f_H$$

## 交流电机 AC motor

下表显示了由环境温度和海拔高度变化而引起的功率调整变化。表中对于交流电机列出了系数和：

The following table shows the power regulation variation caused by changes in ambient temperature and altitude. Tables for AC motors are listed in the coefficients and the definition of work in IEC60034 is as follows:



图7/Chart 7

T=环境温度/Ambient temperature

H=海拔高度/Altitude

## 工作制 Duty cycle

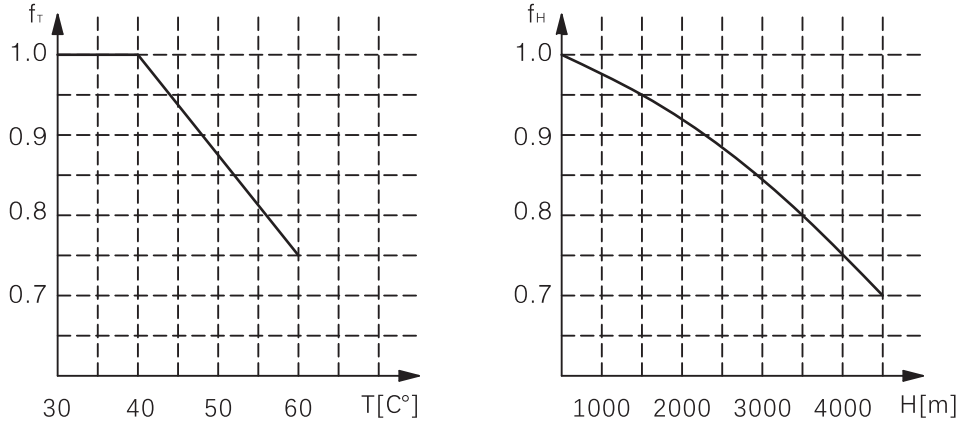
IEC 60034-1 (EN 60034-1) 中定义的工作制如下：

表13 /Table 13

工作制 Duty cycle	注释 Annotations
S1	连续工作制：恒定载荷下运行，电机达到热稳定状态。 Continuous Duty cycle: Stable operation under constant load.
S2	短时运行工作制：在规定的有限时间内恒载运行，随后停机直至电机恢复到环境温度。 Short-time Duty cycle: The motor operates in a limited period of time and then stops until the motor returns to the ambient temperature.
S3	断续周期工作制：起动过程对温升无影响。按一系列相同的工作周期运行。每一周期包括一段恒定负载时间和停转时间，以“负载持续率(cdf)”%表征。 Intermittent working system: Motor start-up process has no effect on temperature rise. Each cycle consists of a constant load time and a stop time, expressed in cdf%
S4-S10	断续周期工作制：起动过程对温升有影响，运行由一系列相同周期构成，每个周期内包括恒载段和暂停段。可用“负载持续率(cdf)”%和每小时起停次数来描述。 Intermittent working system: The starting process of motor has influence on temperature rise. The motor operates in a series of identical operating cycles. Each cycle includes a period of constant load and stop time, expressed in cdf%
	提示/Remark
	对于变频器控制S1工作制通常是假定的；对于每小时很多次循环周期的工况，必须按S9断续周期工作制考虑。 For the inverter control S1, the operating system is usually assumed. For numerous cycle per hour of the working conditions, it must be in accordance with the S9 cycle system.



下图显示了S1、S2和S3工作制：The following figures show the duty cycles of S1, S2 and S3.



图8/Chart 8

### 负载持续率(CDF) Cyclic Duration factor

负载持续率（CDF）是负载持续时间与工作周期持续时间的比值。工作周期时间是运行时间综合加上无电压间歇时间。典型的工作周期时间是10分钟。

It is ratio of cyclic duration factor and working cycle time .The duty cycle time is the run time plus the no-voltage intermittent time. Typical working cycle time is ten minutes.

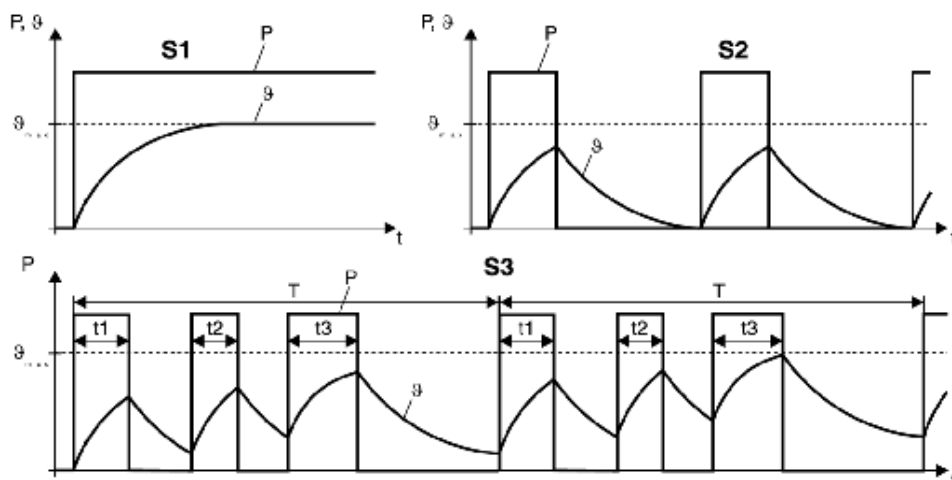
$$CDF = \frac{\text{运行时间总和}(t_1+t_2+t_3)}{\text{工作周期时间}(T)} \times 100[\%]$$

### 功率增长系数K Power growth coefficient K

根据IEC60034(EN60034)电机额定功率只适用于S1（100% CDF）除非有特除规定。如果按S1工作制（100% CDF）设计的电机要在S2“短时运行工作制”或“S3断续周期运行工作制”下运行，允许输出功率应是额定功率与功率增长系列K的乘积。

According to IEC60034 (EN60034) the motor power rating is only applicable to S1 (CDF) 100% unless there are special provisions. If the motor that designed according to S1 working system (100% CDF) wants to run under S2 "Short-time duty operation" or "S3 cycle operating duty", the output power should be the product of the rated power and power growth series coefficient K.

表14 /Table 14

工作制 Duty cycle		功率增长系数K Power growth coefficient K	
S2	运行时间/Working time	60 min	1.1
		30 min	1.2
		10 min	1.4
S3	负载持续率/Cyclic duration factor	60%	1.1
		40%	1.15
		25%	1.3
		15%	1.4
S4-S10	为了确定额定功率和工作制，必须给出每小时启停次数和方式，起动时间、负载时间、制动类型、制动时间、空转时间、周期时间、间歇时间和所需功率/ In order to determine the rated power and work system, it should give out start-stop times and ways, starting time, load time, brake type, braking time, idle time, cycle time, intermittent time and required power in per hour.	根据要求而定 According to the request	

如遇大反向转矩和高转动惯量（高惯量启动）时，请与杰牌公司联系索取精确技术数据。

When encounter big reverse torque and high moment of inertia (high inertia starting), please contact JIE for accurate technical data.



## 50Hz电机用于60Hz电源 50Hz motor can be used to 60Hz power.

设计用50Hz电源的电机在60Hz电源运行时额定数据稍有变化。  
When the motor with 50Hz power is used in the 60Hz power , the rated data changes slightly.

表11/Table 11

50Hz电机电压 50Hz motor voltage	电机连接方式 Motor connection	60Hz电压 60Hz voltage U[V]	额定数据修正值 Rated data correction value			
			$n_N$	$P_N$	$M_N$	$M_A/M_N$
AC220/380V/△/△	△	220	+20%	0%	-17%	-17%
AC220/380V/△/△	△	440	+20%	+20%	0%	0%
AC380/660V/△/△	△					

如果您想将50Hz电机用于60Hz电源请联系杰牌公司。  
If you want to use the 50Hz motor for 60Hz power supply please contact JIE.

## 起动频率 Start frequency

通常电机是根据其热载荷设计，许多情况下电机按S1工作制运行（S1=连续工作制=100%CDF）。根据负载转矩计算出的功率应等于该电机额定功率。

Usually motor is designed according to the thermal load, in many cases the motor according to S1 work system (S1 = continuously work system= 100%CDF). Power should be calculated according to the load torque should be equal to the rated power of the motor.

## 高起动频率 High frequency starting

常遇到采用高起动频率驱动设备如：行走驱动设备。这种情况下选择电机的决定性因素不是所需功率而是电机起动次数。电机每次接通产生高起动电流导致电机温升过高。如果电机产生的热量大于通风系统排放的热量，绕组将过热烧毁。提供电机承受热载荷的能力可以通过选择适当的绝缘等级或采用强制冷风扇。

Often use high frequency starting drive equipment such as: walking drive equipment. Under this circumstance, the decisive factor of choosing the motor is the starting times, not the required power. Every time the motor with a high starting current leads to temperature rise too high. If the heat generated by the motor emission of heat winding is greater than the ventilation system, it will overheat and damage. Under thermal load capacity can provide motor through selecting proper insulation class or using the forced air cooling fan.

## 空载起动频率 $Z_0$ No-load start frequency $Z_0$

杰牌规定电机的许用起动频率为50%CDF（负载持续率）时的空载起动频率 $Z_0$ ， $Z_0$ 表示在50%CDF时且没有反向转矩情况下，每小时允许电机将其转子的转动惯量加速至所需转速的次数。如果加速时有附加转动惯量或存在一个额外的负载转矩，电机的起动时间将增加。这说明电机由于热载荷增大而允许的起动频率降低。

JIE stipulate allowable start frequency of the motor is 50% the CDF (duty cycle) at the time of the no-load speed start frequency  $Z_0$ .  $Z_0$  said at 50% CDF and without anti-torque the allowance times of motor moment of inertia of the rotor speed from to the number of rotation per hour. Speed up to see if there are additional rotational inertia or there is an additional load torque of the motor starting time will increase. This suggests that due to the heat load the motor allows less starting frequency.

### 电机许用起动频率 Z Motor allowable starting frequency Z

电机许用起动频率Z可以用下列公式计算（起停次数/小时即c/h）：

Motor allowable starting frequency Z can use the following formula (start-stop times/h)

$$Z = Z_0 \times K_J \times K_M \times K_P$$

系数 $K_J$   $K_M$ 和 $K_P$ 参考下图：

The coefficients  $K_J$   $K_M$  and  $K_P$  refer to the following figure:



图9 / Chart 9

$J_x$ =附加转动惯量函数  
 $J_z$ =飞轮风扇的转动惯量  
 $J_m$ =电机的转动惯量  
 $M_L$ =加速时反向转矩

$M_H$ =电机加速转矩  
 $P_{stat}$ =加速后所需功率（静态功率）  
 $P_N$ =电机额定功率  
 %cdf=负载持续率

$J_x$ =Additional moment of inertia function  
 $J_z$ =The rotational inertia of the flywheel fan  
 $J_m$ =Momet of Inertia  
 $M_L$ =Accelerated reverse torque

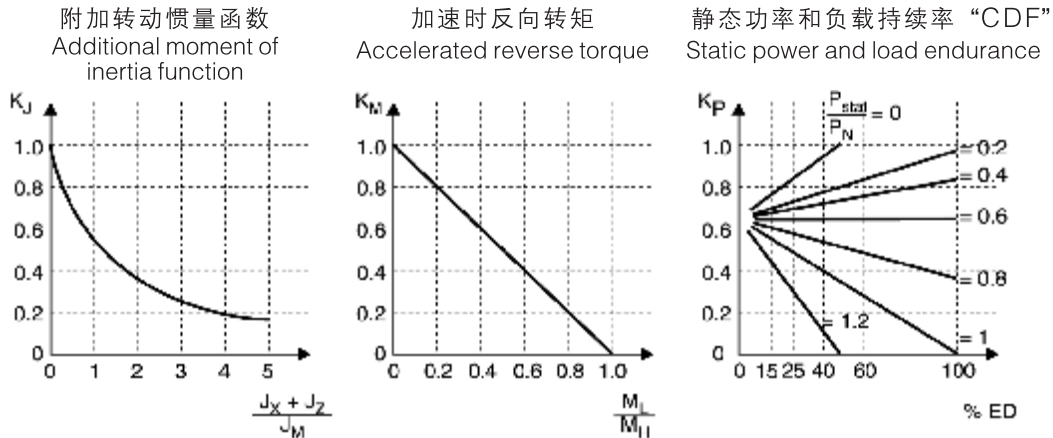
$M_H$ =Motor speed torque  
 $P_{stat}$ =Static power  
 $P_N$ =The motor rated power  
 %CDF=Cyclic duration factor

例如 For example

制动电机JDN71M4/BE/Brake motor JDN71M4/BE

空载起动频率 $Z_0=11000\text{ h}^{-1}$ /No-load starting frequency  $Z_0=11000\text{ h}^{-1}$

1.  $(J_x + J_z)/J_m = 3.5$

$K_J = 0.2$

2.  $M_L/M_H = 0.6$

$K_M = 0.4$

3.  $P_{STAT}/P_N = 0.6$ 和60% cdf

$K_P = 0.65$

$$Z = Z_0 \times K_J \times K_M \times K_P = 11000\text{ h}^{-1} \times 0.2 \times 0.4 \times 0.65 = 572\text{ h}^{-1}$$

周期为6.3s，运行时间为3.8s。

Cycle is 6.3s operation time is 3.8s

### 电机许用起动频率 Motor allowable starting frequency

如果您使用的是制动电机，您必须核实一下制动器在要求的起动频率下使用是否可以。

If you are using a brake motor, you must check whether the brake can be used in the requirements or not under the start frequency

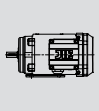
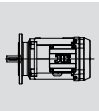

## 4. JD电动机的保护装置 JD Motor Protective Device



### 起停操作 Start-stop operation

如果电机在起停转换操作时必须对开关装置采取适当的抗干扰措施。

If the motor is in start-stop operation, it must take appropriate Anti-interference measures



### 电机的保护 Motor protection

选择正确的保护装置是确保电机安全运行的重要因素。电流保护和电机温度保护是有区别的，电流保护装置包括熔断器或电机断路器。

温度保护装置包括绕组中的PTC热敏电阻或TH双金属片开关（thermostats）当达到绕组的最大许用温度时PTC热敏电阻或双金属片开关就会动作。其特点就是直接检测设定的温度。

Right rotating protection device is an important factor to ensure the safe operation of the motor. Motor protection and motor temperature protection are different, as the motor protection device comprises a fuse or a motor circuit breaker. The temperature protection device comprises a PTC thermistor or a bimetal switch in the winding(thermostats). When the maximum permissible temperature of the winding is reached, the PTC thermistor or bimetal switch will act. It is characterized by the direct detection of the set temperature.

### 电机保护开关 Motor protective switch

通常电机在起停频率低，起停时间短，起停电流小的工作模式下，其断路器可提供充分的过载保护。电机断路器一般设置在电机的额定电流值。在起停频率（>60次/小时）和高起停惯量场合，仅依靠电机断路器来提供保护是不够的。在这种情况下我们推荐使用（PTC）热敏电阻保护器TF。

Usually the motor can provide sufficient overload protection when the starting frequency is low and the starting time is short and the starting current is small. Motor short circuit is generally set in the motor rated current value. It is not enough to rely solely on the motor circuit breaker to provide protection at the starting frequency (>60/h) and the high starting inertia. In this case, we recommend the use of (PTC) thermistor protection TF.

### TF PTC热敏电阻 TF PTC Thermistor

3个（PTC）热敏电阻TF（PTC特性曲线参看DIN 44080）串联在电机内并从接线盒连至变频器的TF/TH输入端或是开关柜内的继电器上。用（PTC）热敏电阻保护器可为电机提供全面的过热保护。采取这种保护装置，电机可用于高惯量起停转换制动运行和不稳定的供电系统。通常电机断路器也和TF一起配合作用。当用变频器控制时JIE建议电机上加装TF。

3 (PTC) thermistor TF (PTC characteristic curve see DIN 44080) series are connected in the motor and from the junction box connected to the input of the inverter TF/TH or switch cabinet on the relay. With (PTC) thermistor protection for the motor to provide full protection against overheating. The motor can be used for high inertia starting braking operation and unstable power supply system. Usually motor circuit breaker and TF work together. When using the inverter control JIE recommend motor installed on the TF.

### TH 双金属片保护开关 TH bimetallic protection switch

3个双金属开关片TH串联在电机绕组内并直接从接线连至电机检测电路中。

The three bimetallic switch sheets TH are connected in series within the motor windings and directly from the wiring to the motor detection circuit.

### 触发温度 Trigger temperature

电机的热保护是通过埋在电机绕组里的TF热敏电阻或TH双金属片开关来实现的。触发温度比电机绝缘等级所能达到的最高保护值要略低一点。TF热敏电阻和TH双金属片开关的触发温度如下表：

The thermal protection of the motor is realized by burying the TF thermistor or TH bimetal switch in the motor winding. The trigger temperature is a little lower than the highest temperature of the motor insulation grade. The trigger temperature of TF thermistor and TH bimetal switch is as follows:

表15 /Table 15

绝缘等级 Insulation Level	触发温度/Trigger temperature TF的额定响应温度/Rated response time of TF TH的额定开关温度/TH rated switching temperature JDN、JDU
155(F)	150°C
180(H)	170°C

## 电感性绕组的安全转换 Safe conversion of inductive winding

注意以下电感性转换。

Note the following inductive conversion

## 低速电机绕组转换 Low speed motor winding conversion

如果电缆布线不当，低速电机绕组转换时产生峰值电压。这种峰值电压可以损坏绕组和触点。为了避免这种情况，可以将连接导线与压敏电阻连在一起。

If the cable is not suitable wiring, peak voltage will happen during the low speed motor winding conversion. This peak voltage can damage the windings and contacts. In order to avoid this situation, the connecting wire can be connected with the varistor.

## 制动线圈的开关 Brake coil switch

盘式制动器直流电路的开关可产生过电压，必须用压敏电阻来消除这种危害。杰牌制动控制系统标准配置中包含压敏电阻。Disc brake DC circuit switch can produce over voltage, It must be used to eliminate this hazard. The standard configuration of the JIE brake control system includes a varistor.

## 开关装置上的保护电路 Protection circuit for switching device

为保护数字或程序逻辑控制器、电机绕组必须要抑制电磁干扰。我们建议在开关装置上安装保护电路以免使电子设备遭到破坏。

In order to protect the digital or program logic controller, the motor winding must suppress the electromagnetic interference. It is recommended that the protective circuit should be installed on the switchgear to avoid damage to the electronic equipment.

## 变频控制 Frequency control

请根据变频器制造商提供的安装操作说明来进行变频操作。

According to the installation instructions provided by the frequency converter manufacturer for frequency conversion operation.

## 变频器控制下的制动电机 Frequency conversion motor controlled by frequency converter

制动电机的制动电缆布线应与其它电源电缆分开，并保持至少200mm的距离。除非制动电缆或电源电缆是带屏蔽的才允许共同布线。

Brake motor cable wiring should be separated from other power cables and maintained at least 200mm distance. Common wiring is allowed unless the brake cable or power cable is shielded.

## 变频器控制测速器的联接 Inverter control the speed of the connection

在联接测速器时请按照以下说明进行

- 只准使用带屏蔽的双绞线电缆。
- 屏蔽两端都通过大的接触面连至PE点位上。
- 信号电缆布线应与电源电缆或制动电缆分开（最短距离为200mm）。

In conjunction with the speedometer,

- Please follow the instructions below.
- Both ends of the shield are connected to the PE point through a large contact surface.
- The signal cable wiring should be separated from the power cable or the brake cable (the shortest distance is 200mm).

## 变频器控制下热敏电阻保护器（TF）的联接

### The connection of thermistor protector (TF) under the control of frequency converter

PTC热敏电阻保护器TF的联接电缆布线应与电源电缆分开，并保持至少200mm的距离。除非TF联接电缆和电源电缆带屏蔽才允许共同布线。

The connection cable wiring of the PTC thermistor protector TF shall be separated from the power cable and maintained at least 200mm distance. Common wiring is not allowed unless the TF connection cable and the power band shield.

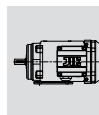
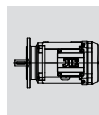

## 六.电气参数

### Electrical parameters

JDN 系列,3 级能效(GB18613-2020) / n=3000rpm-S1 50Hz(IE3-IEC60034-30,IDT)  
 JDN series, level 3 energy efficiency

表1 / Table 1

电机 型号 Type	功率 Power [kW]	转矩 Torque [Nm]	转速 Rated speed [r/min]	电流 Rated current [A]	能效等级 energy efficiency index GB18613-2020	功率因数 power factor cos φ	效率 efficiency [%]	堵转电流 额定电流 Ist/In	堵转转矩 额定转矩 Tsn/Tn	最大转矩 额定转矩 Tmax/Tn	质量 m [kg]	转动惯量 J <sub>mot</sub> [10 <sup>-4</sup> kgm <sup>2</sup> ]
JDN63S2	0.18	0.63	2725	0.53	3	0.78	65.9	5.5	2.2	2.2	6.0	3.6
JDN63M2	0.25	0.87	2755	0.67	3	0.81	69.7	5.5	2.2	2.2	6.8	4.4
JDN71S2	0.37	1.26	2810	0.98	3	0.78	73.8	6.0	2.2	2.2	7.8	3.6
JDN71M2	0.55	1.86	2825	1.33	3	0.81	77.8	6.1	2.3	2.3	9.4	5.0
JDN80S2	0.75	2.51	2855	1.72	3	0.82	80.7	7.0	2.3	2.3	12.3	20.0
JDN80M2	1.1	3.67	2860	2.43	3	0.83	82.7	7.1	2.2	2.3	15.0	25.6
JDN90S2	1.5	4.96	2886	3.26	3	0.83	84.2	7.3	2.2	2.3	19.8	54.7
JDN90L2	2.2	7.2	2905	4.58	3	0.85	85.9	7.5	2.2	2.3	23.2	71.0
JDN100L2	3	9.9	2894	6.16	3	0.85	87.1	7.8	2.2	2.3	33.0	94.4
JDN112M2	4	13.0	2948	8.0	3	0.86	88.1	10.6	2.2	2.3	47.2	183
JDN132S2	5.5	17.9	2935	10.7	3	0.87	89.2	10.0	2.2	2.3	52.0	246
JDN132M2	7.5	24.4	2936	14.8	3	0.85	90.1	9.6	2.2	2.3	53.0	246
JDN160M2	11	35.7	2945	20.6	3	0.89	91.2	8.1	2.0	2.3	115	817
JDN160L2	15	48.6	2945	27.9	3	0.89	91.9	8.1	2.0	2.3	117	817
JDN160H2	18.5	60.1	2940	34.2	3	0.89	92.4	8.2	2.0	2.3	130	1040
JDN180M2	22	71.1	2955	40.5	3	0.89	92.7	8.2	2.0	2.3	155	1630
JDN200L2	30	96.8	2960	54.9	3	0.89	93.3	7.6	2.0	2.3	280	1950
JDN200H2	37	119.4	2960	67.4	3	0.89	93.7	7.6	2.0	2.3	283	2660
JDN225M2	45	144.9	2965	80.8	3	0.90	94.0	7.7	2.0	2.3	323	4350
JDN250M2	55	176.9	2970	98.5	3	0.90	94.3	7.7	2.0	2.3	460	4350
JDN280S2	75	240.8	2975	134.0	3	0.90	94.7	7.1	1.8	2.3	546	8940
JDN280M2	90	288.9	2975	160.0	3	0.90	95.0	7.1	1.8	2.3	630	12000
JDN315S2	110	352.8	2978	195.0	3	0.90	95.2	7.1	1.8	2.3	897	23400
JDN315M2	132	423.3	2978	234.0	3	0.90	95.4	7.1	1.8	2.3	1029	24800
JDN315L2	160	512.8	2980	279.0	3	0.91	95.6	7.2	1.8	2.3	1067	28600
JDN315H2	200	640.9	2980	349.0	3	0.91	95.8	7.2	1.8	2.2	1194	35200

JDN 系列,3 级能效(GB18613-2020) / n=1500rpm-S1 50Hz(IE3-IEC60034-30,IDT)  
 JDN series, level 3 energy efficiency

表2 / Table 2

电机 型号 Type	功率 Power [kW]	转矩 Torque [Nm]	转速 Rated speed [r/min]	电流 Rated current [A]	能效等级 energy efficiency index GB18613-2020	功率 因数 power factor cos φ	效率 efficiency [%]	堵转电流 额定电流 Ist/In	堵转转矩 额定转矩 Tsn/Tn	最大转矩 额定转矩 Tmax/Tn	质量 m [kg]	转动惯量 J <sub>mot</sub> [10 <sup>-4</sup> kgm <sup>2</sup> ]
JDN63S4	0.12	0.8	1390	0.44	3	0.64	64.8	4.4	2.1	2.3	6.0	2.8
JDN63M4	0.18	1.2	1395	0.60	3	0.65	69.9	4.4	2.1	2.3	6.8	3.3
JDN71S4	0.25	1.7	1410	0.78	3	0.66	73.5	5.0	2.1	2.2	7.8	5.1
JDN71M4	0.37	2.5	1415	1.10	3	0.66	77.3	5.1	2.1	2.2	9.4	7.2
JDN80S4	0.55	3.6	1445	1.38	3	0.75	80.8	6.5	2.4	2.3	12.3	17.5
JDN80M4	0.75	4.9	1450	1.87	3	0.74	82.5	7.3	2.3	2.3	15.0	24.6
JDN90S4	1.1	7.2	1455	2.72	3	0.73	84.1	7.5	2.3	2.3	19.8	54.4
JDN90L4	1.5	9.9	1450	3.61	3	0.74	85.3	7.5	2.3	2.3	23.2	66.9
JDN100S4	2.2	14.5	1450	5.1	3	0.76	86.7	7.5	2.3	2.3	27.6	82.0
JDN100L4	3	19.7	1455	6.8	3	0.76	87.7	8.2	2.3	2.3	33.0	111.6
JDN112M4	4	26.2	1460	8.4	3	0.81	88.6	8.2	2.2	2.3	47.2	185.4
JDN132S4	5.5	36.0	1460	11.2	3	0.83	89.6	8.5	2.0	2.3	52.0	225.4
JDN132M4	7.5	48.9	1465	16.1	3	0.78	90.4	8.0	2.0	2.3	88.0	389.9
JDN132L4	9.2	59.8	1470	19.9	3	0.77	91.0	8.5	2.0	2.3	91.2	456.0
JDN160M4	11	71.5	1470	22.5	3	0.81	91.4	7.5	2.2	2.3	121	817
JDN160L4	15	97.1	1475	29.8	3	0.83	92.1	7.8	2.2	2.3	142	1040
JDN180M4	18.5	119.8	1475	35.6	3	0.85	92.6	7.8	2.0	2.3	181	1630
JDN180L4	22	142.4	1475	41.8	3	0.86	93.0	7.8	2.0	2.3	209	1950
JDN200L4	30	193.6	1480	57.3	3	0.85	93.6	7.5	2.0	2.3	285	2660
JDN225S4	37	238.8	1480	69.6	3	0.86	93.9	7.5	2.0	2.3	328	4350
JDN225M4	45	290.4	1480	85.2	3	0.85	94.2	7.5	2.0	2.3	363	4350
JDN250M4	55	354.9	1480	103.9	3	0.85	94.6	7.5	2.2	2.3	442	7360
JDN280S4	75	484.0	1480	141.7	3	0.86	95.0	7.3	2.0	2.3	569	8940
JDN280M4	90	580.7	1480	166.7	3	0.86	95.2	7.3	2.0	2.3	639	12000
JDN315S4	110	707.4	1485	201.4	3	0.87	95.4	7.5	2.0	2.2	939	23400
JDN315M4	132	848.9	1485	240.5	3	0.87	95.6	7.3	2.0	2.2	1033	24800
JDN315L4	160	1029.0	1485	288.4	3	0.88	95.8	7.3	2.0	2.2	1126	28600
JDN315H4	200	1283.6	1488	359.7	3	0.88	96.0	7.3	2.0	2.2	1238	35200





JDN 系列,3 级能效(GB18613-2020) / n=1000rpm-S1 50Hz(IE3-IEC60034-30,IDT)  
 JDN series, level 3 energy efficiency



表3 /Table 3

电机 型号 Type	功率 Power [kW]	转矩 Torque [Nm]	转速 Rated speed [r/min]	电流 Rated current [A]	能效等级 energy efficiency index GB18613-2020	功率 因数 power factor cos φ	效率 efficiency [%]	堵转电流 额定电流 Ist/In	堵转转矩 额定转矩 Tsn/Tn	最大转矩 额定转矩 Tmax/Tn	质量 m [kg]	转动惯量 J <sub>mot</sub> [10 <sup>-4</sup> kgm <sup>2</sup> ]
JDN71S6	0.18	1.9	915	0.62	3	0.69	63.9	3.4	2.2	1.9	7.8	8.3
JDN71M6	0.25	2.6	915	0.81	3	0.68	68.6	3.4	2.3	2.0	9.4	10.4
JDN80M6	0.37	3.8	935	1.12	3	0.68	73.5	4.1	2.4	2.1	15.0	17.1
JDN90S6	0.55	5.4	966	1.67	3	0.65	77.2	5.2	2.8	2.3	19.8	54.0
JDN90M6	0.75	7.5	957	2.12	3	0.68	78.9	4.8	2.4	2.0	19.8	54.0
JDN90L6	1.1	11.0	957	3.08	3	0.67	81.0	5.0	2.8	2.4	23.2	67.4
JDN100L6	1.5	14.9	961	4.4	3	0.63	82.5	4.7	2.9	2.2	33.0	112
JDN112M6	2.2	21.6	973	6.0	3	0.66	84.3	6.5	3.2	2.4	47.2	178
JDN132S6	3	29.4	974	8.1	3	0.66	85.6	6.2	3.4	2.6	52.0	245
JDN132M6	4	39.5	968	10.3	3	0.68	86.8	5.5	3.2	2.5	53.0	245
JDN132L6	5.5	53.9	975	14.8	3	0.64	88.0	5.6	2.8	2.7	91.2	439
JDN160M6	7.5	73.2	979	17.2	3	0.74	89.1	7.0	2.0	2.1	115	817
JDN160L6	11	108.3	970	23.1	3	0.80	90.3	7.2	2.0	2.1	114	1040
JDN180L6	15	146.5	978	30.8	3	0.81	91.2	7.3	2.0	2.1	197	1950
JDN200L6	18.5	180.3	980	37.7	3	0.81	91.7	7.3	2.0	2.1	280	2660
JDN200H6	22	214.4	980	44.6	3	0.81	92.2	7.4	2.0	2.1	283	2660
JDN225M6	30	292.3	980	58.9	3	0.83	92.9	6.9	2.0	2.1	310	4350
JDN250M6	37	358.7	985	71.5	3	0.84	93.3	7.1	2.0	2.1	460	7360
JDN280S6	45	436.3	985	85.6	3	0.85	93.7	7.3	2.0	2.0	520	8940
JDN280M6	55	533.2	985	103.0	3	0.86	94.1	7.3	2.0	2.0	630	12000
JDN315S6	75	727.2	985	143.0	3	0.84	94.6	6.6	2.0	2.0	870	23400
JDN315M6	90	869.9	988	169.0	3	0.85	94.9	6.7	2.0	2.0	941	24800
JDN315L6	110	1063.3	988	206.2	3	0.85	95.1	6.7	2.0	2.0	1020	28600
JDN315H6	132	1275.9	988	243.8	3	0.86	95.4	6.8	2.0	2.0	1140	35200

JDU系列,2级能效(GB18613-2020) / n=3000rpm-S1 50Hz(IE4-IEC60034-30,IDT)  
 JDU series, level 2 energy efficiency

表4 /Table 4

电机 型号 Type	功率 Power [kW]	转矩 Torque [Nm]	转速 Rated speed [r/min]	电流 Rated current [A]	能效等级 energy efficiency index GB18613-2020	功率因数 power factor $\cos \phi$	效率 efficiency [%]	堵转电流 额定电流 Ist/In	堵转转矩 额定转矩 Tsn/Tn	最大转矩 额定转矩 Tmax/Tn	质量 m [kg]	转动惯量 Jmot [10 <sup>-4</sup> kgm <sup>2</sup> ]
JDU63S2	0.18	0.63	2745	0.48	2	0.80	70.8	5.5	2.2	2.2	6.9	7.2
JDU63M2	0.25	0.87	2745	0.63	2	0.81	74.3	5.5	2.2	2.2	7.8	8.8
JDU71S2	0.37	1.28	2765	0.89	2	0.81	78.1	6.1	2.2	2.2	9.0	7.2
JDU71M2	0.55	1.90	2765	1.25	2	0.82	81.5	6.1	2.3	2.3	10.8	10.0
JDU80S2	0.75	2.46	2910	1.66	2	0.82	83.5	7.0	2.3	2.3	14.1	40.0
JDU80M2	1.1	3.60	2920	2.36	2	0.83	85.2	7.3	2.2	2.3	17.3	51.2
JDU90S2	1.5	4.89	2930	3.14	2	0.84	86.5	7.6	2.2	2.3	22.8	109.4
JDU90L2	2.2	7.2	2930	4.47	2	0.85	88.0	7.6	2.2	2.3	26.7	142.0
JDU100L2	3	9.8	2935	5.9	2	0.87	89.1	7.8	2.2	2.3	38.0	188.8
JDU112M2	4	13.0	2940	7.7	2	0.88	90.0	8.3	2.2	2.3	54.3	366
JDU132S2	5.5	17.8	2945	10.4	2	0.88	90.9	8.3	2.0	2.3	59.8	492
JDU132M2	7.5	24.3	2950	14.1	2	0.88	91.7	7.9	2.0	2.3	61.0	492
JDU160M2	11	35.5	2960	20.2	2	0.89	92.6	8.1	2.0	2.3	132	1634
JDU160L2	15	48.4	2960	27.4	2	0.89	93.3	8.1	2.0	2.3	135	1634
JDU160H2	18.5	59.7	2960	33.6	2	0.89	93.7	8.2	2.0	2.3	150	2080
JDU180M2	22	70.9	2965	39.8	2	0.89	94.0	8.2	2.0	2.3	171	3260
JDU200L2	30	96.5	2970	54.0	2	0.89	94.5	7.6	2.0	2.3	308	3900
JDU200H2	37	119.0	2970	66.4	2	0.89	94.8	7.6	2.0	2.3	311	5320
JDU225M2	45	144.5	2975	79.7	2	0.90	95.0	7.7	2.0	2.3	341	8700
JDU250M2	55	176.6	2975	97.2	2	0.90	95.3	7.7	2.0	2.3	506	8700
JDU280S2	75	240.4	2980	132.1	2	0.90	95.6	7.1	2.0	2.3	546	17880
JDU280M2	90	288.2	2982	158.2	2	0.90	95.8	7.1	1.8	2.3	662	24000
JDU315S2	110	352.5	2980	192.9	2	0.90	96.0	7.1	1.8	2.3	914	46800
JDU315M2	132	423.0	2980	231.0	2	0.90	96.2	7.1	1.8	2.3	935	49600
JDU315L2	160	512.8	2980	276.6	2	0.91	96.3	7.2	1.8	2.3	1071	57200
JDU315H2	200	640.9	2980	345.1	2	0.91	96.5	7.2	1.8	2.2	1197	70400





JDU 系列, 2 级能效(GB18613-2020) / n=1500rpm-S1 50Hz(IE4-IEC60034-30,IDT)  
 JDU series, level 2 energy efficiency



表5 / Table 5

电机 型号 Type	功率 Power [kW]	转矩 Torque [Nm]	转速 Rated speed [r/min]	电流 Rated current [A]	能效等级 energy efficiency index GB18613-2020	功率因数 power factor cos φ	效率 efficiency [%]	堵转电流 额定电流 Ist/In	堵转转矩 额定转矩 Tsn/Tn	最大转矩 额定转矩 Tmax/Tn	质量 m [kg]	转动惯量 J <sub>mot</sub> [10 <sup>-4</sup> kgm <sup>2</sup> ]
JDU63S4	0.12	0.9	1340	0.36	2	0.72	69.8	4.4	2.1	2.2	6.9	5.7
JDU63M4	0.18	1.3	1340	0.50	2	0.73	74.7	4.4	2.1	2.2	7.8	6.7
JDU71S4	0.25	1.8	1355	0.66	2	0.74	77.9	5.2	2.1	2.2	9.0	10.3
JDU71M4	0.37	2.6	1355	0.92	2	0.75	81.1	5.2	2.1	2.2	10.8	14.4
JDU80S4	0.55	3.7	1420	1.33	2	0.75	83.9	5.2	2.4	2.3	14.1	35.0
JDU80M4	0.75	5.0	1430	1.77	2	0.75	85.7	6.6	2.3	2.3	17.3	49.2
JDU90S4	1.1	7.3	1445	2.52	2	0.76	87.2	6.8	2.3	2.3	22.8	108.8
JDU90L4	1.5	9.9	1450	3.36	2	0.77	88.2	7.0	2.3	2.3	26.7	133.8
JDU100S4	2.2	14.4	1455	4.6	2	0.81	89.5	7.6	2.3	2.3	31.7	164.1
JDU100L4	3	19.7	1455	6.1	2	0.82	90.4	7.6	2.3	2.3	38.0	223.2
JDU112M4	4	26.2	1460	8.1	2	0.82	91.1	7.8	2.2	2.3	54.3	370.8
JDU132S4	5.5	35.7	1470	10.9	2	0.83	91.9	7.9	2.0	2.3	59.8	450.8
JDU132M4	7.5	48.7	1470	14.6	2	0.84	92.6	7.5	2.0	2.3	101.2	779.8
JDU132L4	9.2	59.6	1475	17.8	2	0.84	93.0	7.7	2.2	2.3	104.9	912
JDU160M4	11	71.2	1475	21.0	2	0.85	93.3	7.8	2.2	2.3	132.3	1634
JDU160L4	15	97.1	1475	28.1	2	0.86	93.9	7.8	2.2	2.3	149.5	2080
JDU180M4	18.5	119.4	1480	34.6	2	0.86	94.2	7.8	2.0	2.3	171	3260
JDU180L4	22	142.0	1480	41.0	2	0.86	94.5	7.8	2.0	2.3	187	3900
JDU200L4	30	193.6	1480	55.7	2	0.86	94.9	7.3	2.0	2.3	308	5320
JDU225S4	37	237.9	1485	68.5	2	0.86	95.2	7.4	2.0	2.3	341	8700
JDU225M4	45	289.4	1485	83.1	2	0.86	95.4	7.4	2.0	2.3	341	8700
JDU250M4	55	353.7	1485	101.3	2	0.86	95.7	7.4	2.2	2.3	506	14720
JDU280S4	75	480.7	1490	134.5	2	0.88	96.0	6.9	2.0	2.3	546	17880
JDU280M4	90	576.8	1490	161.2	2	0.88	96.1	6.9	2.0	2.3	662	24000
JDU315S4	110	705.0	1490	194.5	2	0.89	96.3	7.0	2.0	2.2	914	46800
JDU315M4	132	846.0	1490	233.1	2	0.89	96.4	7.0	2.0	2.2	935	49600
JDU315L4	160	1025.5	1490	282.0	2	0.89	96.6	7.1	2.0	2.2	1071	57200
JDU315H4	200	1281.9	1490	352.1	2	0.89	96.7	7.1	2.0	2.2	1197	70400

JDU系列, 2级能效(GB18613-2020) / n=1000rpm-S1 50Hz(IE4-IEC60034-30, IDT)  
 JDU series, level 2 energy efficiency

表6 / Table 6

电机 型号 Type	功率 Power [kW]	转矩 Torque [Nm]	转速 Rated speed [r/min]	电流 Rated current [A]	能效等级 energy efficiency index GB18613-2020	功率因数 power factor cos φ	效率 efficiency [%]	堵转电流 额定电流 Ist/In	堵转转矩 额定转矩 Tsn/Tn	最大转矩 额定转矩 Tmax/Tn	质量 m [kg]	转动惯量 J <sub>mot</sub> [10 <sup>-4</sup> kgm <sup>2</sup> ]
JDU71S6	0.18	2.0	860	0.59	2	0.66	70.1	4.0	1.9	2.0	9.0	16.6
JDU71M6	0.25	2.8	860	0.75	2	0.68	74.1	4.0	1.9	2.0	10.8	20.8
JDU80M6	0.37	3.9	895	1.03	2	0.70	78.0	4.7	1.9	2.0	17.3	34.2
JDU90S6	0.55	5.9	895	1.43	2	0.72	80.9	4.7	1.9	2.1	22.8	108.0
JDU90M6	0.75	7.5	950	1.94	2	0.71	82.7	6.0	2.0	2.1	22.8	108.0
JDU90L6	1.1	11.0	955	2.71	2	0.73	84.5	6.0	2.0	2.1	26.7	134.8
JDU100L6	1.5	14.9	960	3.6	2	0.73	85.9	6.5	2.0	2.1	38.0	224
JDU112M6	2.2	21.8	965	5.2	2	0.74	87.4	6.6	2.0	2.1	54.3	356
JDU132S6	3	29.5	970	7.0	2	0.74	88.6	6.8	2.0	2.1	59.8	490
JDU132M6	4	39.2	975	9.2	2	0.74	89.5	6.8	2.0	2.1	61.0	490
JDU132L6	5.5	53.9	975	12.3	2	0.75	90.5	7.0	2.0	2.1	104.9	878
JDU160M6	7.5	73.1	980	15.8	2	0.79	91.3	7.0	2.0	2.1	132.3	1634
JDU160L6	11	107.2	980	22.6	2	0.80	92.3	7.2	2.0	2.1	149.5	2080
JDU180L6	15	145.4	985	30.2	2	0.81	92.9	7.3	2.0	2.1	187	3900
JDU200L6	18.5	179.4	985	37.1	2	0.81	93.4	7.3	2.0	2.1	308	5320
JDU200H6	22	213.3	985	43.9	2	0.81	93.7	7.4	2.0	2.1	311	5320
JDU225M6	30	289.4	990	58.1	2	0.83	94.2	6.9	2.0	2.1	341	8700
JDU250M6	37	356.9	990	70.6	2	0.84	94.5	7.1	2.0	2.1	506	14720
JDU280S6	45	434.1	990	84.6	2	0.85	94.8	7.3	2.0	2.0	546	17880
JDU280M6	55	530.6	990	101.9	2	0.86	95.1	7.3	2.0	2.0	662	24000
JDU315S6	75	723.5	990	141.8	2	0.84	95.4	6.6	2.0	2.0	914	46800
JDU315M6	90	868.2	990	167.8	2	0.85	95.6	6.7	2.0	2.0	935	49600
JDU315L6	110	1061.1	990	204.7	2	0.85	95.8	6.7	2.0	2.0	1071	57200
JDU315H6	132	1273.3	990	242.2	2	0.86	96.0	6.8	2.0	2.0	1197	70400



## 七. 机械特性

### Mechanical Properties

#### 电机防护等级 Motor Protection grade

电机外壳防护等级执行标准EN 60034 ( IEC 60034-5 )

杰牌交流电机防护等级以IP55为标配。制动和变频电机以IP54为标配，根据需要还可提供IP55及IP56等级。

Motor shell protection grade standard EN60034 (IEC60034-5).

JIE AC motor protection based on IP55 standard, Brake and variable frequency motor based on IP54 standard, IP55 and IP56 levels can also be provided as required.

表16 /Table 16

IP	防异物等级 Foreign body level	防水等级 Waterproof grade
0	无专门防护 No special protection	无专门防护 No special protection
1	防止直径大于50mm的固体异物进入壳体 Prevention of solid foreign body diameter greater than 50mm into the shell	垂直滴水应无有害影响 Vertical drip should be no harmful effects
2	防止直径大于12mm的固体异物进入壳体 Prevention of solid foreign body diameter greater than 12MM into the shell	当电机从正常位置向任何方向倾斜15度以内任何一角时垂直滴水应无有害影响 There is no harmful effect on the vertical drop of water when the motor is tilted from any direction to any angle within 15 degrees
3	防止直径大于2.5mm的固体异物进入壳体 Prevention of solid foreign body diameter greater than 2.5mm into the shell	防止淋水 Prevention of water drenching
4	防止直径大于1mm的固体异物进入壳体 Prevention of solid foreign body diameter greater than 1mm into the shell	防溅水 Splash proof
5	防尘 Dustproof	防喷水 Spray proof
6	尘密 Dust tight	防强烈喷水 Anti strong spray
7	-	防短时浸水 Short time flooding
8	-	防长期潜水 Long term diving

#### 电机振动 Motor vibration

表17 /Table 17

电机规格 Motor specifications	63S~132L		160M~225M		250M~315L	
	600~1800	>1800~3600	600~1800	>1800~3600	600~1800	>1800~3600
同步转速 r/min Synchronous speed						
振动等级 Vibration level	振动速度有效值,mm/s Effective velocity of vibration					
N	1.8		2.8		3.5	
R	0.71	1.12	1.12	1.8	1.8	2.8
S	0.45	0.71	0.71	1.12	1.12	1.8

注：JD电动机按N级制造，如用户需要也可按R级或S级制造。

Note: the JD series motors are manufactured according to N, and can be manufactured to R or S if the user requires.

## 噪声 Noise

电动机空载时测得的A计权声功率级的噪声数值。

噪声数值的容差为+3dB (A)。

Noise value of A-weighted sound power level measured at no-load of motor.

Tolerance of noise value is +3dB(A).

表18 /Table 18

型号 Motor type	同步转速 ( r/min ) Synchronous speed		
	3000	1500	1000
	噪声 ( dB(A) ) Noise		
JD63	61	52	—
JD71	64	55	54
JD80	62	56	57
JD90	67	59	57
JD100	74	64	61
JD112	77	65	65
JD132	79	71	69
JD160	81	73	73
JD180	83	76	73
JD200	84	76	73
JD225	86	78	74
JD250	89	79	76
JD280	91	80	78
JD315	92	88	83

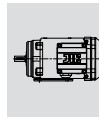
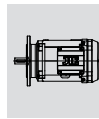

### KS内部防腐保护 KS Corrosion protection

如果电机暴露于室外且无防护措施需增加KS电机内部防腐保护。  
If the motor is exposed outside without protective measures are needs to increase KS corrosion protection



### 轴承型号 Bearing type

下表列出所允许使用的轴承型号：  
The following table lists the types of bearings to be used



表19 /Table 19

电机型号 Motor type	A端轴承(前轴承)IEC电机 A-end beannq(front bearing) IEC motor	B端轴承(后轴承)IEC电机 B-end bearing (Rear bearing) IEC motor	IEC制动电机 IEC Brake motor
JD.63	6202-2Z-C3	6202-2Z-C3	6202-2Z-C3
JD.71	6204-2Z-C3	6203-2Z-C3	6203-2Z-C3
JD.80	6205-2Z-C3	6304-2Z-C3	6304-2Z-C3
JD.90-JD.100	6306-2Z-C3	6205-2Z-C3	6205-2Z-C3
JD.112-JD.132S	6308-2Z-C3	6207-2Z-C3	6207-2Z-C3
JD.132M-JD.132L	6309-2Z-C3	6209-2Z-C3	6209-2Z-C3
JD.160	6309-2Z-C3	6209-2Z-C3	6212-2Z-C3
JD.180	6311-2Z-C3	6211-2Z-C3	6213-2Z-C3
JD.200	6312-2Z-C3	6212-2Z-C3	6213-2Z-C3
JD.225	6313-2Z-C3	6312-2Z-C3	6313-2Z-C3
JD.250-JD.280	6317-2Z-C3	6317-2Z-C3	6317-2Z-C3
JD.315S-JD315M	NU6319	6319-C3	6319-C3
JD.315L-JD315H	NU6319	6319-C3	6322-C3

### 变频控制下JDN、JDU电机的转矩限制曲线

### Torque limit curve of JDN, JDU under variable frequency control

#### 转矩 Torque

在带变频器的JD异步交流电机选型过程中应考虑其转矩的大小，以下几点决定转矩允许值：

- 工作制
- 冷却方式：自冷或强制冷却
- 基频 $f_{base}=50\text{Hz}$  (380V $\Delta$ ) 或 $f_{base}=87\text{Hz}$  (220V $\Delta$ )

转矩限制曲线决定着转矩的大小。所选择的转矩必须小于转矩限制值。下面举例说明了的4极JDN异步电机 ( $f_{base}=50\text{Hz}$ 和 $f_{base}=87\text{Hz}$ ) 的限制曲线。以下为该转矩限制曲线所遵守的条件：

- S1工作制
- 变频器供电电压 $V_{line}=3 \times \text{AC}380\text{V}$
- 电机绝缘等级155 ( F )

The size of the torque should be considered in the process of JD asynchronous motor with frequency converter. The following points determine the allowable torque value

- Duty cycle
- Cooling mode:Self cooling or forced cooling
- Baseband: $f_{base}=50\text{Hz}(380\text{V}\Delta)$  or  $f_{base}=87\text{Hz}(220\text{V}\Delta)$

The torque limit curve determines the torque. The selected torque must be less than the torque limit. The following example illustrates the limits of the 4 pole JDN asynchronous motor. The following is the condition of the torque limit curve:

- duty S1
- Inverter supply voltage $V_{line}=3 \times \text{AC}380\text{V}$
- Motor insulation class155 ( F )

$f_{base}=50\text{Hz}(380\text{V}\Delta/50\text{Hz})$

$f_{base}=50\text{Hz}$ 时的转矩限制曲线如下图所示。自冷电机与强制冷电机(=带强冷风扇)的转矩限制曲线是不同的。

$f_{base}=50\text{Hz}$  torque limit curve as shown below. The torque limiting curve of the self cooling motor and the forced cooling motor (with forced cooling fan) are different.



图10 / Chart 10

- [1] S1工作制自冷(=无强冷风扇) /duty S1 self cooling (no forced cooling fan)
- [2] S1工作制强冷(=带强冷风扇) /duty S1 forced cooling (with forced cooling fan)
- [3] 减速电机的机械极限/Mechanical limit of gear motor

$f_{base}=87\text{Hz}(220\text{V}\Delta/50\text{Hz})$

$f_{base}=87\text{Hz}$ 时的转矩限制曲线如下图所示。自冷电机与强制冷电机(=带强冷风扇)的转矩限制曲线是不同的。

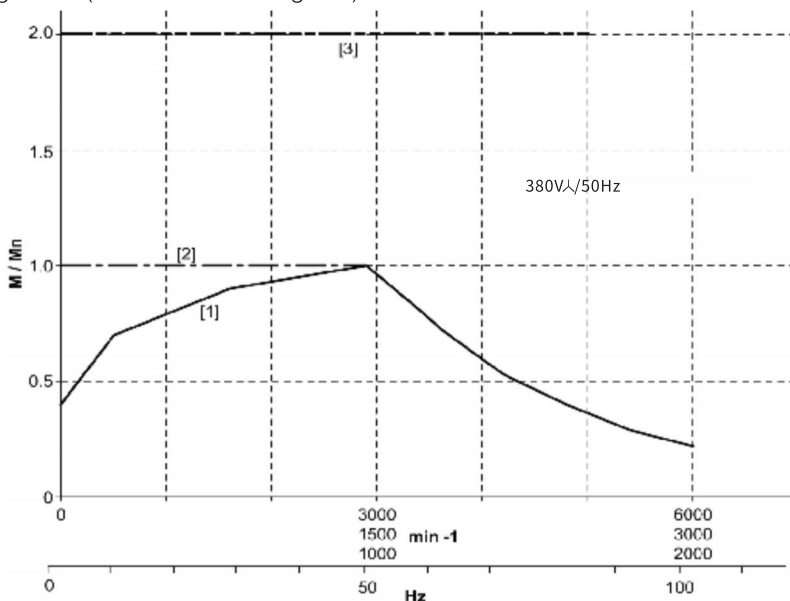
$f_{base}=87\text{Hz}$  torque limit curve as shown below. Self cooling motor and forced cooling motor (with wind fan) the torque limit curve are different.



图11 / Chart 11

- [1] 工作制自冷方式(=无强冷风扇) /Self cooling system
- [2] 工作制强冷方式(=带强冷风扇) /Forced cooling system
- [3] 减速电机的机械极限/Mechanical limit of speed reducer

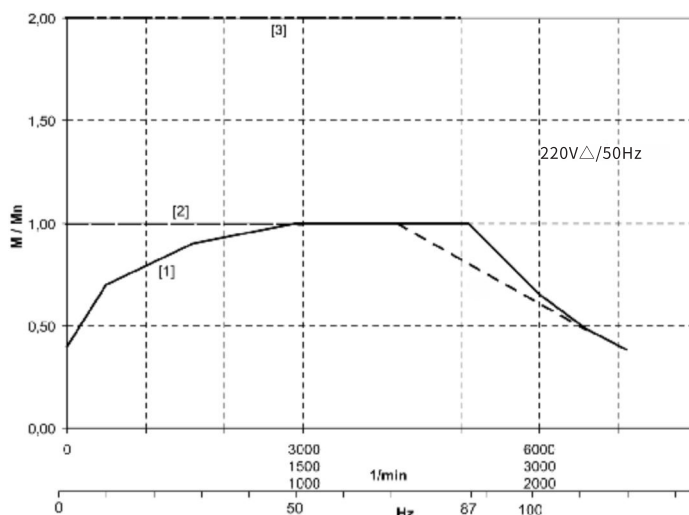

## 八. 产品附件 Product Accessories

### 1. 制动器 Brake

#### 1.1 说明 Description

杰牌电机可根据需要加装电磁式制动器。

电磁式制动器是带直流线圈的励磁盘式制动器结构。制动器原理为断电制动,即通过直流线圈感应的电磁力使制动器释放后,而弹簧产生力使制动器制动。制动器上通过安装手动释放装置来实现机械方式释放,即制动器上可以安装一个释放手柄或释放螺钉。释放手柄会自动复位,而释放螺钉可以使锁紧螺钉来实现机械复位。制动器的接线方式既可直接安装在电机接线柱上也可以安装在开关柜内。

As needed, Our company's electric motor can be equipped with electromagnetic brake as requirement. Electromagnetic brake is a magnetic disc brake structure with DC coil, the brake principle is power off brake, i.e. DC coil induction by the electromagnetic force of the brake release, and spring force to brake. Brake by installing manual release device realize mechanical brake release, which can be mounted on a release handle or release the screw, the release lever will automatically reset and release the screw can be locked screws to achieve reduction. The connection mode of the brake can be directly installed on the motor terminal and can also be installed in the switch cabinet.

#### 1.2 结构图 Construction Diagram



图12/ Chart 12

1.释放螺钉 2.制动器线圈 3.压力盘 4.花键套 5.摩擦盘 6 工作间隙  
Release screws、Coil of brake、Pressure plate、Spline sleeve、Disc friction、Working clearance

### 1.3 性能要求

#### Performance Requirements

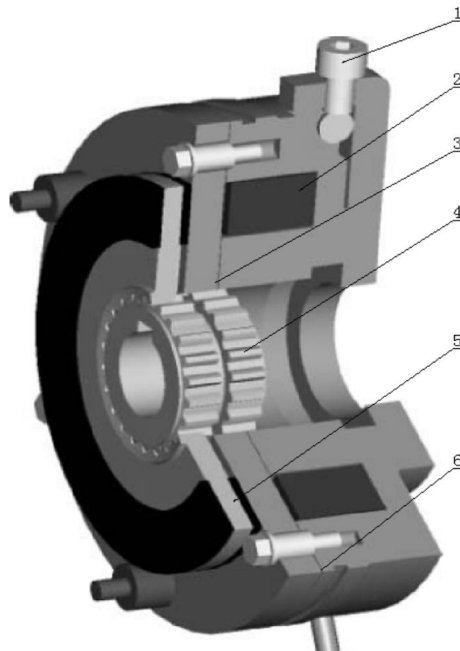
电磁式制动器的外壳防护等级为IP54，制动器的绝缘等级为F级；其绕组温升不得超过105K（电阻法）。

- 电磁式制动器绕组对地应承受历时1分钟的耐压试验而不击穿，其试验频率为50Hz，波形为正弦波，电压的有效值为 $1000V+2U_N$ 。

- 电磁式制动器的绕组对机壳的绝缘电阻在常温下应不低于 $200M\Omega$ 。

电磁式制动器的环境使用温度：

- 电磁式制动器的环境使用温度： $-20^{\circ}C$ 到 $+40^{\circ}C$ 之间，湿度 $\leq 90\%$ ；
- 整流块环境使用温度： $-20^{\circ}C$ 到 $+70^{\circ}C$ 。

电磁式制动器在常规的使用环境下制动器运行噪声应不大于75dB，其测试方案按照GB10069.1规定。

电磁式制动器寿命100万次。JD132以上（包含JD132）制动频率不超过24次/分钟；寿命间隙为20万次。JD160以上（包含JD160）制动频率不超过10次/分钟；寿命间隙10万次。

Electromagnetic brake shell protection class is IP54, the insulation level of the brake is F; The winding temperature rise should not exceed 105K(Electrical resistance).

- The electromagnetic brake winding should withstand 1 minutes of pressure test without breakdown, The test frequency is 50Hz, waveforms is sine wave, voltage effective value is  $1000V+2U_N$ .
- The insulation resistance of the winding of the electromagnetic brake should not be less than  $200M\Omega$ . Ambient temperature of electromagnetic brake:
- Temperature: $-20^{\circ}C$  to  $+40^{\circ}C$ , Humidity $\leq 90\%$ .
- Rectifier block ambient temperature: $-20^{\circ}C$  to  $+70^{\circ}C$ .

The noise of electromagnetic brake should not be more than 75dB under the normal operating environment, in accordance with the provisions of GB10069.

Electromagnetic brake life 1 million times, JD132 above (including JD132) braking frequency of not more than 24 times / minute, Life gap is 200 thousand times. JD160 above (including JD160) braking frequency is not more than 10 times / minute; Life gap 100 thousand times.

标准电磁式制动器电机制动响应时间满足表20规定。

The brake response time of the standard electromagnetic brake motor meets the requirements of Table 20.

表20 /Table 20

机座号 Frame Size	制动时间(直流侧断电 额定间隙下)ms Braking time (DC side power rated gap)/ms	制动时间(交流侧断电 额定间隙下)ms Braking time (AC side power rated gap)/ms
JD.63../BE	$\leq 15$	$\leq 60$
JD.71../BE	$\leq 25$	$\leq 150$
JD.80../BE	$\leq 40$	$\leq 170$
JD.90.7100../BE	$\leq 90$	$\leq 230$
JD.112.7132../BE	$\leq 100$	$\leq 300$
JD.160../BE	$\leq 150$	$\leq 500$
JD.180../BE	$\leq 150$	$\leq 900$
JD.200../225../BE	$\leq 150$	$\leq 1000$
JD.250../280../BE	$\leq 180$	$\leq 1200$
JD.315../BE	$\leq 180$	$\leq 1500$

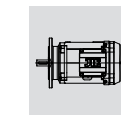



标准电磁式制动电机参数

Standard electromagnetic brake motor parameters



标准制动电机制动力矩参照表21, 表22, 表23:

Standard brake motor braking torque Refer to Table 21, Table 22, Table 23

2P-2 (n=3000rpm) 电机制动力矩参数

2P-2(n=3000rpm)Motor braking torque parameters



表21 /Table 21

功率/Power (kW)	机座号 RameSize	制动器力矩 Braketorque(N·m)
0.18	JD.63S2/BE	3.5
0.25	JD.63M2/BE	3.5
0.37	JD.71S2/BE	3.5
0.55	JD.71M2/BE	3.5
0.75	JD.80S2/BE	10
1.1	JD.80M2/BE	10
1.5	JD.90S2/BE	14
2.2	JD.90L2/BE	20
3	JD.100L2/BE	40
4	JD.112M2/BE	40
5.5	JD.132S2/BE	55
7.5	JD.132S2/BE	80
11	JD.160M2/BE	110
15	JD.160M2/BE	150
18.5	JD.160L2/BE	250
22	JD.180M2/BE	300
30	JD.200L2/BE	300
37	JD.200L2/BE	300
45	JD.225M2/BE	500
55	JD.250M2/BE	500
75	JD.280S2/BE	800
90	JD.280M2/BE	800
110	JD.315S2/BE	1200
132	JD.315M2/BE	1200
160	JD.315L2/BE	1200
200	JD.315H2/BE	2000

2P-4(n=1500rpm)电机制动力矩参数

2P-4(n=1500rpm)Motor braking torque parameters

表22 / Table 22

功率/Power (kW)	机座号 RameSize	制动器力矩 Brake torque (N · m)
0.12	JD.63S4/BE	3.5
0.18	JD.63M4/BE	3.5
0.25	JD.71S4/BE	3.5
0.37	JD.71M4/BE	5
0.55	JD.80S4/BE	10
0.75	JD.80M4/BE	10
1.1	JD.90S4/BE	14
1.5	JD.90L4/BE	20
2.2	JD.100S4/BE	40
3	JD.100L4/BE	40
4	JD.112M4/BE	55
5.5	JD.132S4/BE	80
7.5	JD.132M4/BE	110
9.2	JD.132L4/BE	110
11	JD.160M4/BE	150
15	JD.160L4/BE	250
18.5	JD.180M4/BE	300
22	JD.180L4/BE	300
30	JD.200L4/BE	400
37	JD.225S4/BE	600
45	JD.225M4/BE	600
55	JD.250M4/BE	800
75	JD.280S4/BE	1200
90	JD.280M4/BE	1200
110	JD.315S4/BE	2000
132	JD.315M4/BE	2000
160	JD.315L4/BE	3000
200	JD.315H4/BE	3000

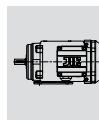
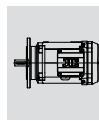

2P-6(n=1000rpm)电机制动力矩参数

2P-6(n=1000rpm)Motor braking torque parameters



表23 /Table 23

功率/Power (kW)	机座号 RameSize	制动器力矩 Brake torque (N · m)	功率/Power (kW)	机座号 RameSize	制动器力矩 Brake torque (N · m)
0.18	JD.71S6/BE	3.5	15	JD.180L6/BE	300
0.25	JD.71M6/BE	5	18.5	JD.200L6/BE	300
0.37	JD.80M6/BE	10	22	JD.200L6/BE	400
0.55	JD.90S6/BE	10	30	JD.225M6/BE	600
0.75	JD.90S6/BE	14	37	JD.250M6/BE	600
1.1	JD.90L6/BE	20	45	JD.280S6/BE	800
1.5	JD.100L6/BE	20	55	JD.280M6/BE	1200
2.2	JD.112M6/BE	40	75	JD.315S6/BE	1200
3	JD.132S6/BE	55	90	JD.315M6/BE	2000
4	JD.132S6/BE	80	110	JD.315L6/BE	3000
5.5	JD.132L6/BE	110	132	JD.315H6/BE	3000
7.5	JD.160M6/BE	150			

#### 1.4 控制系统原理图 Control system schematic

电磁式制动器供电电源既可以单独提供，也可以由电机接线端子供电。

只有单速的电机，其制动器控制系统才可以在电机供电系统中引线。为方便客户使用，杰牌公司在电机出厂时已将制动器控制电源接好，制动器电源直接从电机接线柱上引取，当电机得电时电机运转，制动器也同时释放，当电机断电时电机停止，制动器也同时锁紧。接法见图13，图14，图15。另外，如果制动器是从电机接线端子供电的，那么电机的残余电压会导致延时制动。

变极调速电机和变频器控制的电机，其制动控制器的供电电源必须单独供电。杰牌公司出厂时均不接线，客户实际使用时具体接线接法见图15。

The power supply of the electromagnetic brake can be supplied separately, or can be supplied by the motor terminal. Only the motor has been factory brake control power supply is connected. JIE connect the brake control's power before the motors delivered as for the customer's convenience, when the motor is energized when the motor operates, the brake releasing it at the same time, when the motor power when the motor stops, the brake also lock. The specific method is shown in Figure 13, figure 14, figure 15. in addition, if the brake is from the motor terminal power supply, then the motor residual voltage will lead to delay braking. The motor of the variable speed motor and the inverter control, the power supply of the brake controller must be supplied separately. JIE company does not connect the factory, the actual use of the customer when the connection is shown in Figure 15.

### 制动器快速制动 Quick brake

通过改变整流块的接线方式，可使制动器变为快速制动运行。具体接法见图13，图14，图15。

备注：客户如未提出快速制动要求，杰牌公司按照普通制动作为默认的标准接线方式；客户在实际使用快速制动时，客户需将普通制动拆除后，按照快速制动接线方法接线。

客户未提出变频要求，杰牌公司按照单速电机作为默认的标准接线方式，客户需变频器供电时，客户需将标准接线拆除后，按照图15接线。

By changing the connection mode of the rectifier block, the brake can be changed into a fast braking operation. Refer to table 13, table 14, table 15.

Note: When the customer does not make a quick braking requirement, JIE use the leather brake as the default action of the standard wiring; customers use of fast braking in the actual, customers need to dismantle the ordinary brake.

If customers do not require for of frequency conversion, JIE company use a single speed motor as the default standard wiring mode, customers need inverter power supply, customers need to remove the standard wiring, and connect wiring in accordance with figure 15.

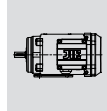
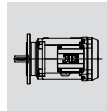

编号 Series number	单速电机电压 及接线 Single – speed motor voltage and wiring	制动器电压 Brake voltage	制动器接法/Brake connection	
			普通制动/Ordinary brake	快速制动/Fast brake
1	220V Δ	220V		
2		380V		
3	380V Y	220V		
4		380V		

图13 / Chart 13

编号 Series number	单速电机电压 及接线 Single - speed motor voltage and wiring	制动器电压 Brake voltage	制动器接法/Brake connection	
			普通制动/Ordinary brake	快速制动/Fast brake
1	380V $\Delta$	220V	<p>电机电源 Motor power supply <math>U=380V_{ac}</math></p> <p>制动电源 Brake power <math>U=220V_{ac}</math></p> <p>接触器 Contactor</p> <p>制动器线圈 Brake coil</p>	<p>电机电源 Motor power supply <math>U=380V_{ac}</math></p> <p>制动电源 Brake power <math>U=220V_{ac}</math></p> <p>接触器 Contactor</p> <p>制动器线圈 Brake coil</p>
		380V	<p>电机电源 Motor power supply <math>U=380V_{ac}</math></p> <p>接触器 Contactor</p> <p>制动器线圈 Brake coil</p>	<p>电机电源 Motor power supply <math>U=380V_{ac}</math></p> <p>接触器 Contactor</p> <p>制动器线圈 Brake coil</p>
3	660V Y	220V	<p>电机电源 Motor power supply <math>U=660V_{ac}</math></p> <p>制动电源 Brake power <math>U=220V_{ac}</math></p> <p>接触器 Contactor</p> <p>制动器线圈 Brake coil</p>	<p>电机电源 Motor power supply <math>U=660V_{ac}</math></p> <p>制动电源 Brake power <math>U=220V_{ac}</math></p> <p>接触器 Contactor</p> <p>制动器线圈 Brake coil</p>
		380V	<p>电机电源 Motor power supply <math>U=660V_{ac}</math></p> <p>接触器 Contactor</p> <p>制动器线圈 Brake coil</p>	<p>电机电源 Motor power supply <math>U=660V_{ac}</math></p> <p>接触器 Contactor</p> <p>制动器线圈 Brake coil</p>

图14 / Chart 14



图15 / Chart 15



## 2. 编码器 Encoder

杰牌可根据需要为客户提供带编码器电机，编码器型号由客户指定。我公司提供的编码器电机结构分为以下六种。如有定制，请详询杰牌公司。

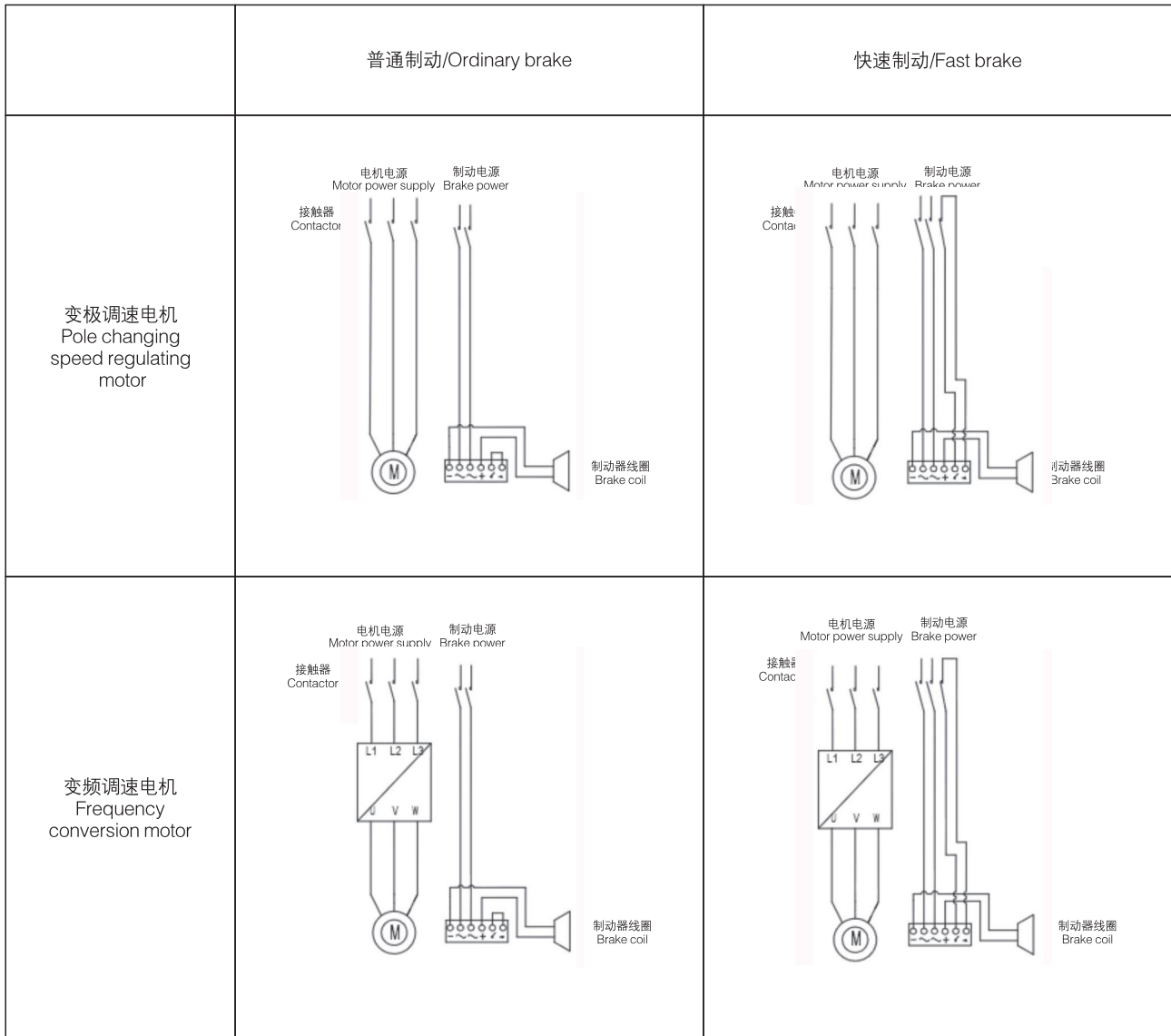
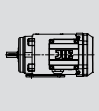
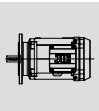
Our company can provide encoder motor to customers as requirement according to need, the encoder model is specified by the customer. JIE provide the following six kinds of the encoder motor. please refer to JIE for any customization.

JD../ES 空心轴与标准电机连接结构  
JD../ES Hollow shaft and standard motor connection structure

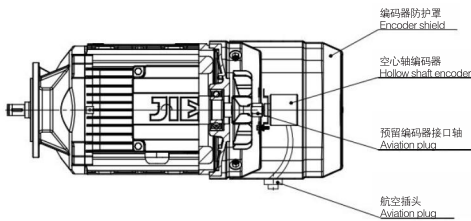

JD../BE/ES 空心轴与带制动电机连接结构  
JD../BE/ES Hollow shaft with brake motor connection structure

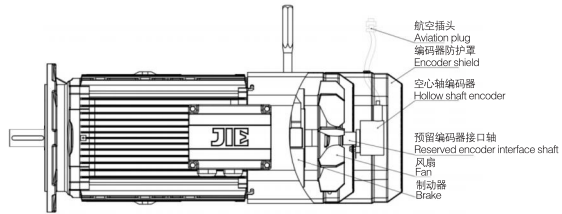

JD../V/ES 空心轴与带风机电机连接结构  
JD../V/ES Hollow shaft and belt motor connection structure

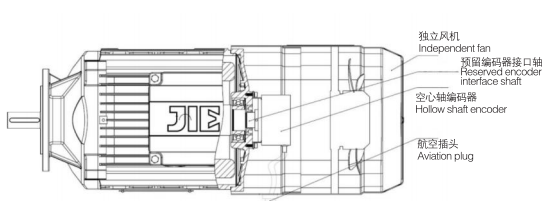

JD../BE/V/ES 空心轴与带制动及风机电机连接结构  
JD../BE/V/ES Hollow shaft with brake and fan motor connection structure

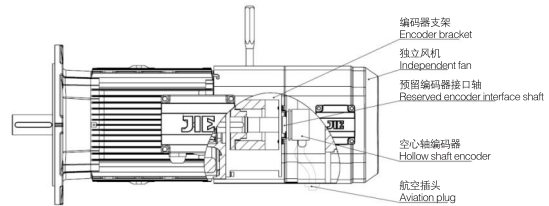

JD../V/EV 实心轴与带风机连接结构  
JD../V/EV Solid shaft and belt connection structure

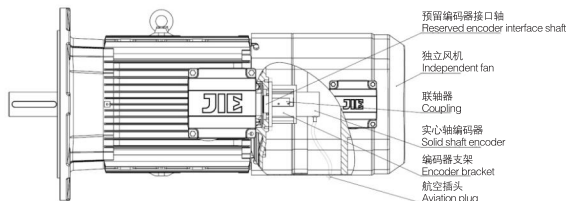

JD../BE/V/EV 实心轴与带风机电机连接结构  
JD../BE/V/EV Solid shaft and belt motor connection structure

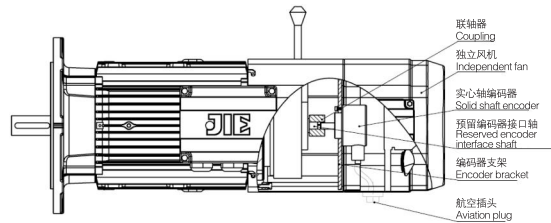



### 3. 强冷风扇 Forced Cooling Fan

#### 代号 Code

V标准设计

V Standard design

#### 描述 Description

强冷风扇用于确保电机在不同转速时的冷却。即电机可以在低速时满载运行而不会产生电机过热风险。带强冷风扇时原普通 PVC 风扇将从电机上拆除。强冷风扇的长度取决于不同的电机附件选项如制动器或编码器。与以前一样罩子上也允许开孔如制动器手动释放孔等。

Forced cooling fan is used to ensure the cooling of the motor at different speeds. That is, the motor can run at full speed without the risk of overheating. The original PVC fan will be removed from the motor when the forced cooling fan is equipped. The length of the forced cooling fan depends on the different motor attachment options, such as brakes or encoders. Cover as before and also allow openings such as manual brake release hole.

根据需要电机可以安装强冷风扇。工频连续运行工况时不需要加强冷风扇。杰牌建议下述情况时采用强冷风扇：

- 高启动频率时（启动次数 $\geq 5$ 次/h）
- 电机带高惯量飞轮Z（飞轮风扇）
- 调速范围在5~35Hz之间
- 变频调速时调速范围 $\geq 1:20$
- 变频调速时在低速甚至是零速时需输出额定力矩

As needed, the motor can be installed with a forced cooling fan. No need to install the forced cooling fan when continuous operation condition. JIE suggest in the following situations :

- High startup frequency
- Motor with high inertia flywheel Z (flywheel fan)
- Speed range from 5 to 35Hz
- Frequency control speed range $\geq 1:20$
- When the speeds is low or even zero speed, the output torque is required

下图为典型的动态变频控制速度-转矩特性图

The following is a typical dynamic frequency control speed- The torque characteristic diagram



图16 / Chart 16

$M_N$ =电机额定扭矩/Rated torque

$M_{max}$ =电机最大扭矩/Maximum torque

$n_{base}$ =电机额定转速/Rated speed

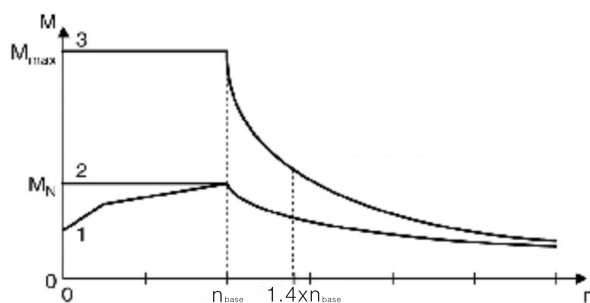
1=带自冷风扇/Self cooling fan

2=带强冷风扇/Forced cooling fan

3=最大扭矩/Maximum torque

当转速位于 $0-n_{base}$ 时负载扭矩位于曲线1以上时需加强冷风扇否则电机将过热

When the speed located at  $0-n_{base}$ , the load torque located in the curve for more than 1 hours, at this time, in order to prevent overheating of the motor, it will be need to install a forst cooling fan.

#### 与编码器组合 Encoder combination

强冷风扇能与所有编码器组合使用，请参考编码器信息章节。请注意电机整体尺寸将可能变得更长。

Forced cooling fan can be used in combination with all encoders, Encoder information please see chapter 3. Note that the overall size may be longer



## 强冷风扇技术参数 Technical datas of forced cooling fan

 三相,  $U=380V_{AC}$ ,  $f=50Hz$   
 Three phase  $U=380V_{AC}$ ,  $f=50Hz$ 

表24 /Table 24

强冷风机 Forced cooling fan 对应电机机座号 The corresponding motor frame size	功率 Power (W)	风压 Wind pressure (Pa)	电流 Current (A)	转速 Rotate speed (r/min)	风量 Blowing rate ( $m^3/h$ )
JD63..	25	42	0.12	2800	98
JD63../BE					
JD71..	25	42	0.12	2800	98
JD71../BE					
JD80..	30	42	0.13	2800	98
JD80../BE					
JD90..	42	82	0.18	2800	265
JD90../BE					
JD100..	52	82	0.18	2800	265
JD100../BE					
JD112/132..	60	110	0.2	2800	306
JD112/132../BE					
JD160..	80	110	0.21	2800	485
JD160../BE					
JD180..	100	130	0.32	1400	660
JD180../BE					
JD200..	150	65	0.48	1350	1679
JD200../BE					
JD225..	200	70	0.6	1350	1786
JD225../BE					
JD250..	300	110	0.9	1350	1900
JD250../BE					
JD280..	400	130	1.2	1350	2000
JD280../BE					
JD315..	450	130	1.35	1350	2500
JD315../BE					

 单相,  $U=220V_{AC}$ ,  $f=50Hz$   
 Single phase  $U=220V_{AC}$ ,  $f=50Hz$ 

表25 /Table 25

强冷风机 Forced cooling fan 对应电机机座号 The corresponding motor frame size	功率 Power (W)	风压 Wind pressure (Pa)	电流 Current (A)	转速 Rotate speed (r/min)	风量 Blowing rate ( $m^3/h$ )
JD63..	25	42	0.16	2800	98
JD63../BE					
JD71..	25	42	0.16	2800	98
JD71../BE					
JD80..	30	42	0.18	2800	98
JD80../BE					
JD90..	42	82	0.3	2800	265
JD90../BE					
JD100..	52	82	0.35	2800	265
JD100../BE					
JD112/132..	60	110	0.38	2800	306
JD112/132../BE					
JD160..	80	110	0.43	2800	485
JD160../BE					
JD180..	130	130	0.7	1400	660
JD180../BE					
JD200..	160	65	1	1350	1679
JD200../BE					
JD225..	220	70	1.38	1350	1786
JD225../BE					
JD250..	300	110	1.88	1350	1900
JD250../BE					
JD280..	400	130	2.50	1350	2000
JD280../BE					
JD315..	450	130	2.81	1350	2500
JD315../BE					

三相,  $U=380V_{AC}$ ,  $f=60Hz$   
Three phase  $U=380V_{AC}$ ,  $f=60Hz$

表26 / Table 26

强冷风机 Forced cooling fan 对应电机机座号 The corresponding motor frame size	功率 Power (W)	风压 Wind pressure (Pa)	电流 Current (A)	转速 Rotate speed (r/min)	风量 Blowing rate ( $m^3/h$ )
JD63..	30	45	0.21	3000	108
JD63../BE					
JD71..	30	45	0.21	3000	108
JD71../BE					
JD80..	35	45	0.22	3000	108
JD80../BE					
JD90..	55	88	0.25	3000	290
JD90../BE					
JD100..	60	88	0.26	3000	290
JD100../BE					
JD112/132..	75	120	0.3	3000	335
JD112/132../BE					
JD160..	90	120	0.4	3000	530
JD160../BE					
JD180..	120	130	0.38	1680	660
JD180../BE					
JD200..	200	65	0.64	1620	1679
JD200../BE					
JD225..	230	70	0.69	1620	1786
JD225../BE					
JD250..	330	110	0.99	1620	2090
JD250../BE					
JD280..	440	130	1.32	1620	2200
JD280../BE					
JD315..	500	130	1.50	1620	2750
JD315../BE					

单相,  $U=220V_{AC}$ ,  $f=60Hz$   
Single phase  $U=220V_{AC}$ ,  $f=60Hz$

表27 / Table 27

强冷风机 Forced cooling fan 对应电机机座号 The corresponding motor frame size	功率 Power (W)	风压 Wind pressure (Pa)	电流 Current (A)	转速 Rotate speed (r/min)	风量 Blowing rate ( $m^3/h$ )
JD63..	30	45	0.16	3000	108
JD63../BE					
JD71..	30	45	0.16	3000	108
JD71../BE					
JD80..	35	45	0.21	3000	108
JD80../BE					
JD90..	55	88	0.32	3000	290
JD90../BE					
JD100..	60	88	0.35	3000	290
JD100../BE					
JD112/132..	75	120	0.45	3000	335
JD112/132../BE					
JD160..	90	120	0.6	3000	530
JD160../BE					
JD180..	155	130	0.83	1680	660
JD180../BE					
JD200..	220	65	1.38	1620	1679
JD200../BE					
JD225..	250	70	1.56	1620	1786
JD225../BE					
JD250..	330	110	2.06	1620	2090
JD250../BE					
JD280..	440	130	2.75	1620	2200
JD280../BE					
JD315..	500	130	3.13	1620	2750
JD315../BE					

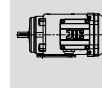
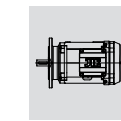

## 4. 高惯量飞轮 High Inertia Flywheel



### 代号 Code

Z 高惯量飞轮 Z High Inertia Flywheel



### 描述 Description

电机安装高惯量飞轮Z（飞轮风扇）从而实现电机在主控制下平滑地起制动。  
高惯量飞轮Z使电机转动惯量增加 $J_z$ 。  
制动和非制动电机均可安装高惯量飞轮Z。

The motor is installed with high inertia flywheel Z (flywheel fan) so as to realize the smooth braking of the motor under the main control.

High inertia flywheel Z will increase the motor inertia  $J_z$ .

High inertia flywheel Z can be installed in both braking and non braking motors.

### 重要注意事项

- 计算起动频率时，空载许用频率需乘以0.8，或是加强冷风扇。
- 电机转动惯量 $J_{ges}=J_{mot}+J_z$
- 不允许反接制动或反向冲击制动。
- 不允许用于振动级别B的工况。

### Important Notices

- When calculating the starting frequency, No-load allowable frequency is multiplied by 0.8 or install a forced cooling fan
- Motor moment of inertia  $J_{ges}=J_{mot}+J_z$
- Do not allow reverse or reverse impact braking
- Do not allow Vibration level B

表28 /Table 28

电机规格 Motor specifications	$J_z$ [ $10^{-4}$ kgm <sup>2</sup> ]	$J_{mot}$ [ $10^{-4}$ kgm <sup>2</sup> ]	$J_{mot}+J_z$ [ $10^{-4}$ kgm <sup>2</sup> ]	质量/Quality [kg]
JD.71S4	21.3	5.1	26.4	1.3
JD.71M4		7.2	28.5	
JD.80S4	37.9	17.5	55.4	1.8
JD.80M4		24.6	62.5	
JD.90S4	100	54.4	154.4	3.4
JD.90L4		66.9	166.9	
JD.100S4	135	82	217	3.5
JD.100L4		111.6	246.6	
JD.112M4	200	185.4	385.4	4.5
JD.132S4		225.4	425.4	
JD.132M4	300	389.9	689.9	6.4
JD.132L4		456	756	

## 5. 防护罩 Protective Cowl

### 代号 Code

C 防护罩 C Cowl protect

### 描述 Description

防护罩用于防止雨水进入风扇罩。主要应用于垂直安装位置时。

The protective cowl is used for preventing rain water from entering the fan cowl. Mainly used in vertical installation position.

当电机出轴垂直向下安装时，液体和固体异物很容易进到电机风扇罩内，杰牌提供保护罩可以对电机很好的加以保护。  
制动电机出轴垂直向下安装时，必须订购保护罩C，同样在户外的出轴向下的电机必须安装保护罩C。

When the motor is installed vertically down the shaft, the liquid and solid foreign body is easy to enter into the motor fan cowl, and the JIE provides a protective cowl to protect the motor.

When the motor shaft is installed vertically downwards, it is necessary to order the protective cover C, and the motor must be fitted with a protective cowl C.

## 6. 2WE双轴伸电机 2WE Biaxial Extension Motor

### 代号 Code

2WE 双轴伸电机 2WE Biaxial Extension Motor

### 描述 Description

杰牌公司可根据需要为客户提供2WE双轴伸电机，具体结构尺寸如下图

If required, JIE can provide 2WE dual-axes motors with structure sizes below:

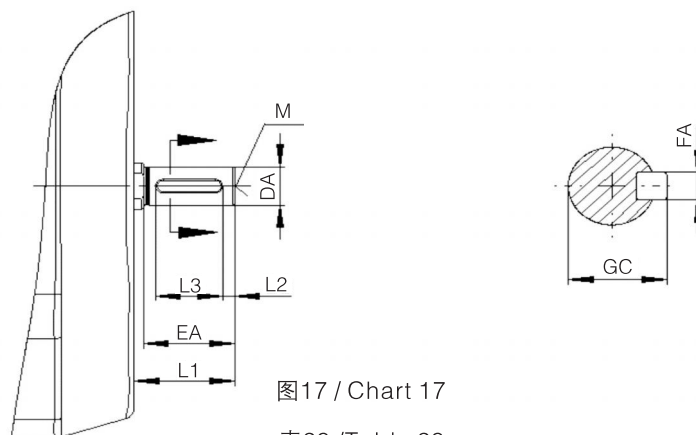

机座号 FrameSize	DA	FA	GC	EA	L1	L2	L3	M
JD.63../71../2WE	11	4	12.5	23	25	3.5	16	M4
JD.80../90../100../2WE	14	5	16	30	32	4	22	M5
JD.112../132../2WE	19	6	21.5	40	43.5	4	32	M6
JD.160../2WE	28	8	31	60	64	5	50	M10
JD.180../2WE	48	14	51.5	110	115	10	80	M16
JD.200../225../2WE	55	16	59	110	115	10	90	M20
JD.250../280../2WE	55	16	59	110	117	10	90	M20
JD.315../2WE	70	20	74.5	140	143	7.5	125	M20

## 7. 无风扇设计 Fanless Design

### 代号 Code

U 无风扇设计

U Without fan design

### 描述 Description

对于代号U电机B端端盖封闭无风扇和无风罩。可以防止脏物、水和粉尘等进入电机。此电机转子特殊。对于带制动电机转子轴不是在轴承后截断，而是延伸到花键套配合尺寸后截断。在制动器线圈后端采用封盖密封。普通电机和制动电机有2种不带风扇的冷却方式，仅靠对流冷却的电机必须在减小载荷或断续工作制时使用。

For the U motor B end cover closes without fan and cover .It can prevent dirt, water and dust into the machine. This motor has special rotors. The motor rotor shaft with brake is not cut off behind the bearing, but extends to the fit size of spline . Use end cover seals behind the brake coil.Motor/Break motor has two cooling ways without fans, the motor/break motor can rely on the convection for cooling only when reduce work load or intermittent brake.

自冷电机功率通常为风扇冷却电机的一半，如有问题请与杰牌联系。

The power of the non-ventilated motor is usually half of cooling fan motor, if there is any question, please contact JIE.

## 8. 带恒温器保护装置 With Thermostat Protection Device



### 代号 Code

TH 恒温器保护

TH With thermostat protection device



### 描述 Description

电机热保护用于防止电机过热而引起的电机损坏可选择监测两个温度级别的155 ( F ) 和180 ( H )。

TH为三个一组设计，即电机每相均有一只NC触电的温度调节开关并串联在一起。

当温度达到额定值时，TH双金属开关组合断开并采用接触器或反馈系统停止电机。当电机开始冷却时，在额定温度时TH不会立即恢复闭合。但是当温度下降到额定温度的40K ( 重设温度RST )

以下时，TH重新闭合。

The motor thermal protection can prevent motor from overheating damage and choose to monitor the two temperature levels of 155 (F) and 180 (H).

Three TH for one group, each phase has a NC electric shock temperature control switch and in series together.

When the temperature reaches rating, TH bimetallic switch combination will disconnect and uses the contactor or feedback system to stop the motor. When the motor begins to cool down, TH will not restore closure immediately with the rated temperature. But when the temperature decreases to the rated temperature of 40 k (reset temperature ,RST), the TH closes again.

当绕组温度超过允许温度时，温度金属开关断开，可连接到驱动检测回路中。

When the winding temperature exceed the permitted temperature, the metal temperature switch will disconnect and can be connected in the drive detection circuit.

表30 /Table 30

	AC V	DC V	
电压VoltageU [V]	250	60	24
电流 (cos φ = 1.0) [A] Electric current	2.5	1.0	1.6
电流 (cos φ = 0.6) [A] Electric current	1.6	-	-
接触电阻最大1ohm为DC5V/1mA The maximum contact resistance 1ohm is DC5V/1mA			

双金属开关“NC”的开合条件

The conditions of bimetallic switch "NC" opening and closing



图18 / Chart 18

RST 重设温度/Reset temperature

NST 额定开关温度/The rated temperature switch

## 9. PT100电机热保护 Motor Thermal Protection

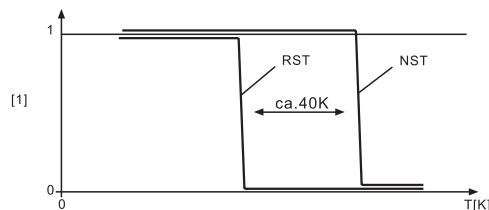
### 代号 Code

PT 热保护

PT Thermal protection

### 描述 Description

PT热保护装置可连续检测电机温度，并可在变频器或控制器内进行进一步处理。与KTY半导体传感器不同，PT100采用铂金属传感器，具有接近线性的特性曲线，并有更高的精度。

/PT附件不能替代标准的电机保护TF或TH。

仅当变频器具有电机热模型功能时，采用变频器+/PT组合具有电机热保护的功能。

- 1 表示定子内预埋1只传感器
- 3 表示定子内预埋3只传感器（每相1只）

PT thermal protection device can continuously measure the motor temperature, and can be within the inverter or controller for further processing. Unlike KTY semiconductor sensor, PT100 is made by platinum metal, it has the nearly linear characteristic curve, and has a higher precision. PT attachment cannot replace the standard motor protection TF or TH. Only when the inverter has the motor thermal model function, adopting frequency converter + PT has the motor thermal protection function.

- Mean to embed one sensor in the stator.
- Mean to embed 3 sensors in the stator(one piece for one phase).

PT100温度传感器可连续检测电机温度。根据需要可选择1只或3只PT100传感器。

PT100 temperature sensor can test motor temperature continuously. According to the need that it can rotate 1 or 3 pcs 100 pt100 sensors.

表31 / Table 31

技术参数 Technical Data	PT100
联接 Connect	红/白 Red / White
20-25°C 每个PT100的阻值 The resistance of each PT100	107Ω < R < 110Ω
检测电流 The test current	< 3mA

### PT100特征曲线 PT100 characteristic curve



图19 / Chart 19



## 九. 产品尺寸 Product Dimension

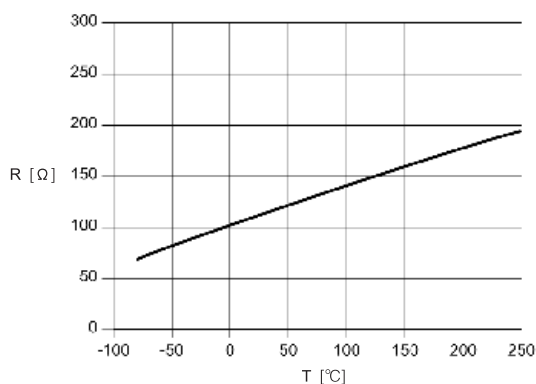
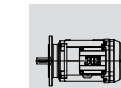

### JD电动机/制动电机的尺寸表 JD series AC motor / brake motor dimensions table



#### 关于尺寸表的注意事项 Notes on the dimensions table

请遵循以下有关4极JD电动机（制动）的尺寸表的注意事项：

- 电机尾部至少余留风扇罩半径的距离以避免阻碍通风。
- 对于制动电机需为拆卸风扇罩预留空间（风扇罩直径）。
- 制动器手动释放有多种角度可选,如下图所示。

可选四个角度0°、90°、180°或270°。

Please follow the notices about the size of the 4 class JD AC motor

- Motor rear should keep a space more than the radius of the fan cover as to avoid hindering the ventilation.
- For brake motors, space is required to remove the fan cowl(diameter of the fan cover).
- Brake manual release has a variety of angles, as shown below. Four Options available.



图20 / Chart 20

制动器手动释放默认安装角度为相对于电机接线盒270°。若未定义则默认手动释放位置随电机接线盒旋转。手动释放可能会以90°为单位旋转。若带强冷风扇（V），则手动释放位置会受到强冷风扇的影响。

Brake manual release angle for the motor junction box is installed by default to 270°. If don't define default manual release lever position will be rotating with the motor junction box. Manual release may rotate by 90°. With a forced cooling fan(V), the manual release position will be affected.

### 制动电机带强冷风扇时 Brake motor with forced cooling fan

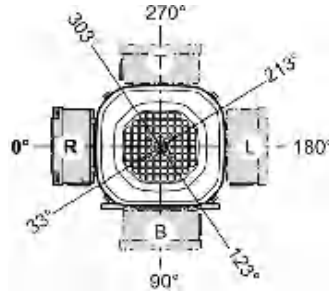
表32 /Table 32

机座号 Motor Frame size	对于不同接线盒角度所允许的手动释放角度 Manual release angle allowed for different junction box angles			
	0° (R)	90° (B)	180° (L)	270° (T)
63..BE../V	90°, 180°, 270°	90°, 180°, 270°	90°, 180°, 270°	90°, 180°, 270°
71..BE../V				
80..BE../V				
90..BE../V				
100..BE../V				
112..BE../V				
132..BE../V				
160..BE../V	0°, 90° 180°, 270°	0°, 90° 180°, 270°	0°, 90° 180°, 270°	0°, 90° 180°, 270°
180..BE../V				
200..BE../V				
225..BE../V				
250..BE../V				
280..BE../V				
315..BE../V				



## 公差 Tolerance

中心高 Center height

下列公差应用于所给出的尺寸表

The following tolerances applied to the size of the given table

$h \leq 250\text{mm}$  →  $-0.5\text{mm}$

$h > 250\text{mm}$  →  $-1\text{mm}$

轴公差 The shaft tolerance

直径公差

The diameter tolerance

$\varnothing \leq 28\text{mm}$  → ISO j6

$\varnothing \leq 50\text{mm}$  → ISO k6

$\varnothing > 50\text{mm}$  → ISO m6

按照DIN332标准JD型中心孔

According to the type DIN332 standard JD center hole

$\varnothing = 7-10\text{mm}$  → M3

$\varnothing > 10-13\text{mm}$  → M4

$\varnothing > 13-16\text{mm}$  → M5

$\varnothing > 16-21\text{mm}$  → M6

$\varnothing > 21-24\text{mm}$  → M8

$\varnothing > 24-30\text{mm}$  → M10

$\varnothing > 30-38\text{mm}$  → M12

$\varnothing > 38-50\text{mm}$  → M16

$\varnothing > 50-85\text{mm}$  → M20

$\varnothing > 85-130\text{mm}$  → M24

$\varnothing > 130\text{mm}$  → M30

键符合DIN6885标准 (圆头平键)

Key DIN6885 standard (round head flat key)

## 法兰 Flange

止口公差

The seam allowance tolerance

$\varnothing \leq 230\text{mm}$  (法兰规格A120-A300) → ISO j6

$\varnothing > 230\text{mm}$  (法兰规格A350-A660) → ISO h6

每个型号的交流(制动)电机都有不同尺寸的法兰可选。每个型号的不同法兰尺寸见相应的尺寸表

Each type of AC motor has a different optional of the flange sizes. See the kinds of flange sizes for the appropriate size of each type.

## 起吊螺栓及吊耳 Lifting bolt and lug

JD.90及以下的电机供货时不提供吊装工具。JD.100及以上电机配置可拆卸吊耳。

JD. 90 and below the motor does not provide lifting tools. JD100 and above motor provide configuration.

## 电机附件 Motor accessories

安装附件后电机尺寸可能改变请参考电机附件尺寸图纸

The dimension of the motor may be changed after fitting the attachment. Please refer to the drawing of the motor dimension.

## 特殊设计 Special design

由于特殊设计或需要预留宽泛的附件接口接线盒尺寸可能与标准尺寸偏差很多。请留意杰牌的订单确认单。

Because of the special design or the need, the size may be a bit deviation from the standard size. Please pay attention to JIE's order confirmation.

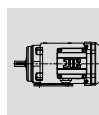
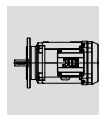

附录A (规范性附录) Appendix A (normative appendix)  
机座带底脚, 不带法兰的电动机 With feet and without flange

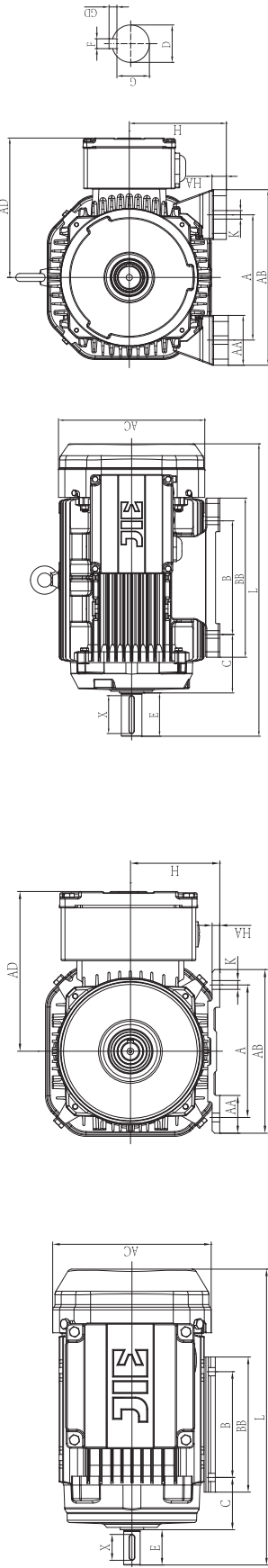

机座号/Frame Size: 100-315

机座号/Frame Size: 63-90

机座号 Frame Size JD.63...315../B3		外形及安装尺寸/Overall and mounting dimensions(mm)																	X
A	AA	AB	AC	AD	B	BB	C	D	E	F	G	H	HA	K	L		X		
63S4	100	31	127	120	108	80	110	40	Φ11	23	4	8.5	63	4.5	4-Φ7	218	16		
63M4																			
71S4	112	30	130	135	127	90	115	45	Φ14	30	5	11	71	6	4-Φ7	252	22		
71M4																			
80S4	125	36	165	156	137	100	140	50	Φ19	40	6	15.5	80	6	4-Φ10	322	32		
80M4																			
90S4	140	32	180	177.5	149	125	155	56	Φ24	50	8	20	90	6	4-Φ10	335	40		
90L4	140	32	180	177.5	156	125	155	56	Φ24	50	8	20	90	6	4-Φ10	395	40		
100S4	160	30	189	198	156	140	165	63	Φ28	60	8	24	100	9	4-Φ12	420	50		
100L4																			
112M4	190	46	220	221	171	140	208	70	Φ28	60	8	24	112	7.5	4-Φ12	452	50		
132S4	216	42	246	221	171	140	216	89	Φ38	80	10	33	132	12	4-Φ12	522	70		
132M4																			
132L4	216	42	242	263	228	178	200	89	Φ38	80	10	33	132	10	4-Φ12	552	70		
160M4	254	65	314	314	251	210	260	108	Φ42	110	12	37	160	20	4-Φ145	608	90		
160L4	254	65	314	314	251	210	304	108	Φ42	110	12	37	160	20	4-Φ145	652	90		
180M4	279	70	349	355	268.5	241	349	121	Φ48	110	14	42.5	180	22	4-Φ145	716	80		
200L4	279	70	349	355	268.5	279	387	121	Φ48	110	14	42.5	180	22	4-Φ145	764	80		
200L4	318	70	388	397	290	305	369	133	Φ55	110	16	49	200	25	4-Φ185	777	90		
225S4	356	75	431	446	312	286	368	149	Φ60	140	18	53	225	28	4-Φ185	820	100		
225M4	356	75	431	446	312	311	393	149	Φ60	140	18	53	225	28	4-Φ185	845	100		
250M4	406	80	484	485	358	349	445	168	Φ65	140	18	58	250	30	4-Φ24	910	125		
280S4	457	85	542	547	387	368	485	190	Φ75	140	20	67.5	280	35	4-Φ24	982	125		
280M4	457	85	542	547	387	419	536	190	Φ75	140	20	67.5	280	35	4-Φ24	1033	125		
315S4	508	120	628	620	527	406	570	216	Φ80	170	22	71	315	45	4-Φ28	1224	160		
315M4	508	120	628	620	527	457	680	216	Φ80	170	22	71	315	45	4-Φ28	1334	160		
315L4	508	120	628	620	527	508	680	216	Φ80	170	22	71	315	45	4-Φ28	1334	160		
315H4	508	120	628	620	527	508	680	216	Φ80	170	22	71	315	45	4-Φ28	1334	160		

附录B (规范性附录) Appendix B (normative appendix)

机座不带底脚, 带法兰的电动机 Without feet and with flange

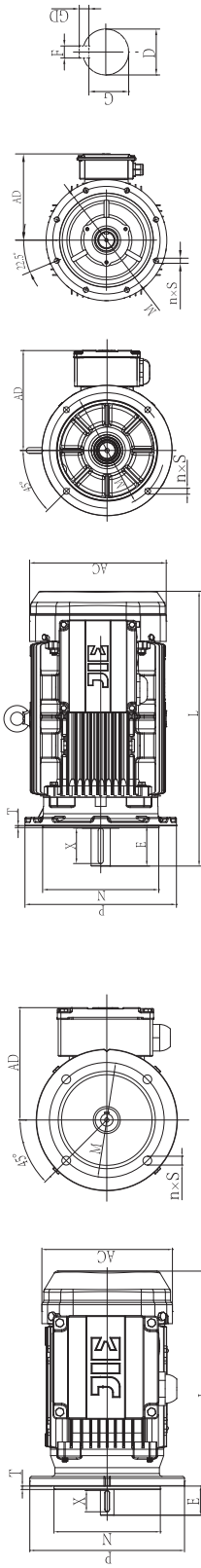

机座号/Frame Size: 225-315

机座号/Frame Size: 63-90

机座号 Frame Size JD.63..-315../B3	法兰号 The flange	外形及安装尺寸/Overall and mounting dimensions(mm)														
		AC	AD	D	E	F	G	M	N	P	S	T	L	X		
63S4	FF115	120	108	Φ11	23	4	8.5	Φ115	Φ95	Φ140	4×Φ10	3	218	16		
63M4																
71S4	FF130	135	127	Φ14	30	5	11	Φ130	Φ110	Φ160	4×Φ10	3.5	252	22		
71M4																
80S4	FF165	156	137	Φ19	40	6	15.5	Φ165	Φ130	Φ200	4×Φ12	3.5	322	32		
80M4																
90S4	FF165	177.5	149	Φ24	50	8	20	Φ165	Φ130	Φ200	4×Φ12	3.5	335	40		
90L4	FF165	177.5	156	Φ24	50	8	20	Φ165	Φ130	Φ200	4×Φ12	3.5	395	40		
100S4	FF215	198	156	Φ28	60	8	24	Φ215	Φ180	Φ250	4×Φ14.5	4	420	50		
100L4																
112M4	FF215	221	171	Φ28	60	8	24	Φ215	Φ180	Φ250	4×Φ14.5	4	452	50		
132S4	FF265	221	171	Φ38	80	10	33	Φ265	Φ230	Φ300	4×Φ14.5	4	522	70		
132M4																
132L4	FF265	263	228	Φ38	80	10	33	Φ265	Φ230	Φ300	4×Φ14.5	4	552	70		
160M4	FF300	315	251	Φ42	110	12	37	Φ300	Φ250	Φ350	4×Φ18.5	5	609	90		
160L4	FF300	315	251	Φ42	110	12	37	Φ300	Φ250	Φ350	4×Φ18.5	5	653	90		
180M4	FF300	355	268.5	Φ48	110	14	42.5	Φ300	Φ250	Φ350	4×Φ18.5	5	716	80		
180L4	FF300	355	268.5	Φ48	110	14	42.5	Φ300	Φ250	Φ350	4×Φ18.5	5	764	80		
200L4	FF350	397	290	Φ55	110	16	49	Φ350	Φ300	Φ400	4×Φ18.5	5	777	90		
225S4	FF400	446	312	Φ60	140	18	53	Φ400	Φ350	Φ450	8×Φ18.5	5	820	100		
225M4	FF400	446	312	Φ60	140	18	53	Φ400	Φ350	Φ450	8×Φ18.5	5	845	100		
250M4	FF500	485	358	Φ65	140	18	58	Φ500	Φ450	Φ550	8×Φ18.5	5	910	125		
280S4	FF500	547	387	Φ75	140	20	67.5	Φ500	Φ450	Φ550	8×Φ18.5	5	982	125		
280M4	FF500	547	387	Φ75	140	20	67.5	Φ500	Φ450	Φ550	8×Φ18.5	5	1033	125		
315S4	FF600	620	527	Φ80	170	22	71	Φ600	Φ550	Φ660	8×Φ24	6	1224	160		
315M4	FF600	620	527	Φ80	170	22	71	Φ600	Φ550	Φ660	8×Φ24	6	1334	160		
315L4	FF600	620	527	Φ80	170	22	71	Φ600	Φ550	Φ660	8×Φ24	6	1334	160		
315H4	FF600	620	527	Φ80	170	22	71	Φ600	Φ550	Φ660	8×Φ24	6	1334	160		

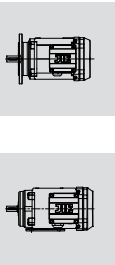

### 附录C (规范性附录) Appendix C (normative appendix) 机座带底脚带法兰的电动机 With feet and flange

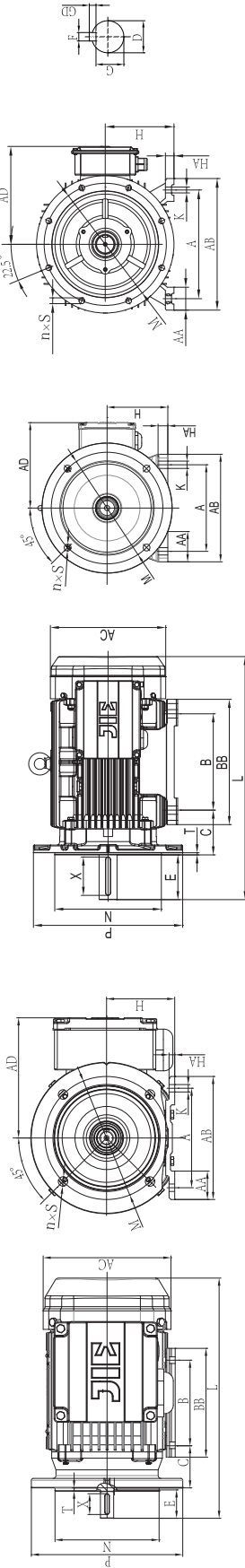

机座号/Frame Size: 225-315

机座号/Frame Size: 100-200

机座号/Frame Size: 63-90

机座号 Frame Size JD.63..~315../B3		外形及安装尺寸/Overall and mounting dimensions(mm)																				
法兰号 The flange	A	AA	AB	AC	AD	B	BB	C	D	E	F	G	H	HA	K	M	N	P	S	T	L	X
63S4	100	31	127	120	108	80	110	40	Φ11	23	4	8.5	63	4.5	4-Φ7	Φ115	Φ95	Φ140	4×Φ10	3	218	16
63M4																						
71S4	112	30	130	135	127	90	115	45	Φ14	30	5	11	71	6	4-Φ7	Φ130	Φ110	Φ160	4×Φ10	3.5	252	22
71M4																						
80S4	125	36	165	156	137	100	140	50	Φ19	40	6	15.5	80	6	4-Φ10	Φ165	Φ130	Φ200	4×Φ12	3.5	322	32
80M4																						
90S4	140	32	180	177.5	149	125	155	56	Φ24	50	8	20	32	6	4-Φ10	Φ165	Φ130	Φ200	4×Φ12	3.5	335	40
90L4	140	32	180	177.5	156	125	155	56	Φ24	50	8	20	32	6	4-Φ10	Φ165	Φ130	Φ200	4×Φ12	3.5	395	40
100S4	160	30	189	198	156	140	165	63	Φ28	60	8	24	30	9	4-Φ12	Φ215	Φ180	Φ250	4×Φ14.5	4	420	50
100L4																						
112M4	190	46	220	221	171	140	208	70	Φ28	60	8	24	46	7.5	4-Φ12	Φ215	Φ180	Φ250	4×Φ14.5	4	452	50
132S4	216	42	246	221	171	140	216	89	Φ38	80	10	33	42	12	4-Φ12	Φ265	Φ230	Φ300	4×Φ14.5	4	522	70
132M4																						
132L4	216	42	242	263	228	178	200	89	Φ38	80	10	33	42	10	4-Φ12	Φ265	Φ230	Φ300	4×Φ14.5	4	552	70
160M4	254	65	314	314	251	210	260	108	Φ42	110	12	37	65	20	4-Φ14.5	Φ300	Φ250	Φ350	4×Φ18.5	5	609	90
160L4	254	65	314	314	251	210	304	108	Φ42	110	12	37	65	20	4-Φ14.5	Φ300	Φ250	Φ350	4×Φ18.5	5	653	90
180M4	279	70	349	355	268.5	241	349	121	Φ48	110	14	42.5	70	22	4-Φ14.5	Φ300	Φ250	Φ350	4×Φ18.5	5	716	80
180L4	279	70	349	355	268.5	279	387	121	Φ48	110	14	42.5	70	22	4-Φ14.5	Φ300	Φ250	Φ350	4×Φ18.5	5	764	80
200L4	318	70	388	397	290	305	369	133	Φ55	110	16	49	70	25	4-Φ18.5	Φ350	Φ300	Φ400	4×Φ18.5	5	777	90
225S4	356	75	431	446	312	286	368	149	Φ60	140	18	53	75	28	4-Φ18.5	Φ400	Φ350	Φ450	8×Φ18.5	5	820	100
225M4	356	75	431	446	312	311	393	149	Φ60	140	18	53	75	28	4-Φ18.5	Φ400	Φ350	Φ450	8×Φ18.5	5	845	100
250M4	406	80	484	485	358	349	445	168	Φ65	140	18	58	80	30	4-Φ24	Φ500	Φ450	Φ550	8×Φ18.5	5	910	125
280S4	457	85	542	547	387	368	485	190	Φ75	140	20	67.5	85	35	4-Φ24	Φ500	Φ450	Φ550	8×Φ18.5	5	982	125
280M4	457	85	542	547	387	419	536	190	Φ75	140	20	67.5	85	35	4-Φ24	Φ500	Φ450	Φ550	8×Φ18.5	5	1033	125
315S4	508	120	628	620	527	406	570	216	Φ80	170	22	71	120	45	4-Φ28	Φ600	Φ550	Φ660	8×Φ24	6	1224	160
315M4	508	120	628	620	527	457	680	216	Φ80	170	22	71	120	45	4-Φ28	Φ600	Φ550	Φ660	8×Φ24	6	1334	160
315L4	508	120	628	620	527	508	680	216	Φ80	170	22	71	120	45	4-Φ28	Φ600	Φ550	Φ660	8×Φ24	6	1334	160
315H4	508	120	628	620	527	508	680	216	Φ80	170	22	71	120	45	4-Φ28	Φ600	Φ550	Φ660	8×Φ24	6	1334	160

附录 D (规范性附录) Appendix D (normative appendix)

机座不带底脚, 带法兰的电动机 Without feet and with flange

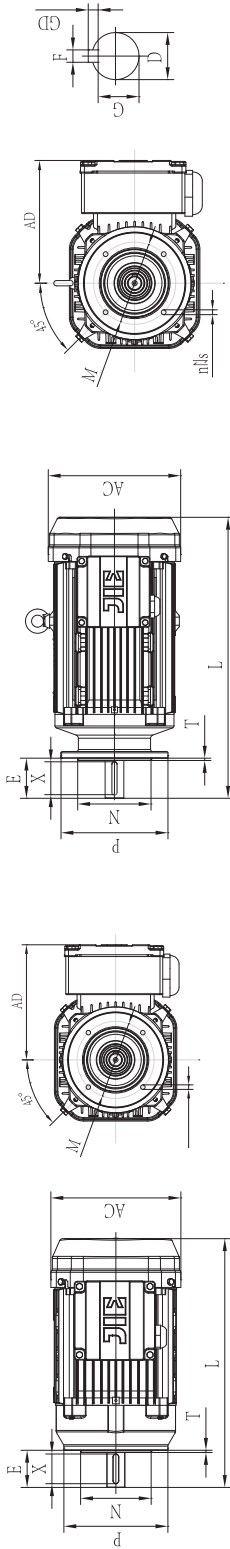

机座号/Frame Size: 63-90

机座号/Frame Size: 100-112

机座号 Frame Size JD.63.-112./B14	法兰号 The flange	外形及安装尺寸/Overall and mounting dimensions(mm)													
		AC	AD	D	E	F	G	M	N	P	S	T	L	X	
63S4	FT75	120	108	Φ11	23	4	8.5	Φ75	Φ60	Φ90	4 × M5	2.5	218	16	
63M4															
71S4	FT85	135	127	Φ14	30	5	11	Φ85	Φ70	Φ105	4 × M6	2.5	252	22	
71M4															
80S4	FT100	156	137	Φ19	40	6	15.5	Φ100	Φ80	Φ120	4 × M6	3	322	32	
80M4															
90M4	FT115	177.5	149	Φ24	50	8	20	Φ115	Φ95	Φ140	4 × M8	3	335	40	
90L4	FT115	177.5	156	Φ24	50	8	20	Φ115	Φ95	Φ140	4 × M8	3	395	40	
100S4	FT130	198	156	Φ28	60	8	24	Φ130	Φ110	Φ160	4 × M8	3.5	420	50	
100L4															
112M4	FT130	221	171	Φ28	60	8	24	Φ130	Φ110	Φ160	4 × M8	3.5	452	50	

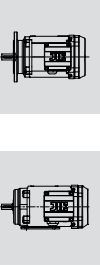

## 附录E (规范性附录) Appendix E (normative appendix)

变频电动机 Variable frequency motor

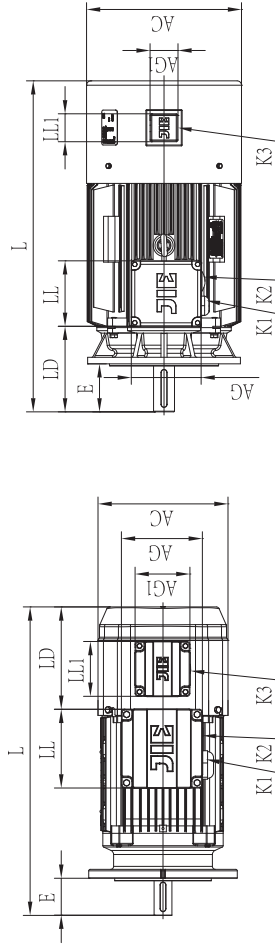

机座号/Frame Size: 63-132

机座号/Frame Size: 160-315

机座号 Frame Size JD.63..-315..	外形及安装尺寸/Overall and mounting dimensions(mm)											
	E	LL	LD	LL1	AG1	AG	AC	L	K1	K2	K3	
63S4	23	92	102	74	74	92	120	278	M20×1.5	M16×1.5	M20×1.5	
63M4												
71S4	30	106	108	74	74	109	135	314	M20×1.5	M16×1.5	M20×1.5	
71M4												
80S4	40	106	124	74	74	109	156	394	M25×1.5	M16×1.5	M20×1.5	
80M4												
90S4	50	106	136	74	74	109	177.5	413	M25×1.5	M16×1.5	M20×1.5	
90L4	50	106	136	74	74	109	177.5	473	M25×1.5	M16×1.5	M20×1.5	
100S4	60	106	136	74	74	109	198	498	M32×1.5	M16×1.5	M20×1.5	
100L4												
112M4	60	106	148	74	74	109	221	515	M32×1.5	M16×1.5	M20×1.5	
132S4	80	106	148	74	74	109	221	585	M32×1.5	M16×1.5	M20×1.5	
132M4												
132L4	80	182	124	74	74	152	263	619	2-M40×1.5	2-M16×1.5	M20×1.5	
160M4	110	152	180	74	74	162	314	643	M40×1.5	M40×1.5	M20×1.5	
160L4	110	152	180	74	74	162	314	687	M40×1.5	M40×1.5	M20×1.5	
180M4	110	150	196	74	74	160	355	751	M36×2	M36×2	M20×1.5	
180L4	110	150	196	74	74	160	355	799	M36×2	M36×2	M20×1.5	
200L4	110	188	202	74	74	208	397	825	M48×2	M48×2	M20×1.5	
225S4	140	188	232	74	74	208	446	879	M48×2	M48×2	M20×1.5	
225M4	140	188	232	74	74	208	446	904	M48×2	M48×2	M20×1.5	
250M4	140	218	246	74	74	248	485	975	M63×1.5	M63×1.5	M20×1.5	
280S4	140	218	246	74	74	248	547	1057	M63×1.5	M63×1.5	M20×1.5	
280M4	140	218	246	74	74	248	547	1108	M63×1.5	M63×1.5	M20×1.5	
315S4	170	280	257	74	74	320	620	1314	M63×1.5	M63×1.5	M20×1.5	
315M4	170	280	257	74	74	320	620	1424	M63×1.5	M63×1.5	M20×1.5	
315L4	170	280	257	74	74	320	620	1424	M63×1.5	M63×1.5	M20×1.5	
315H4	170	280	257	74	74	320	620	1424	M63×1.5	M63×1.5	M20×1.5	

附录F (规范性附录) Appendix F (normative appendix)

带制动的电动机 Motor with brake

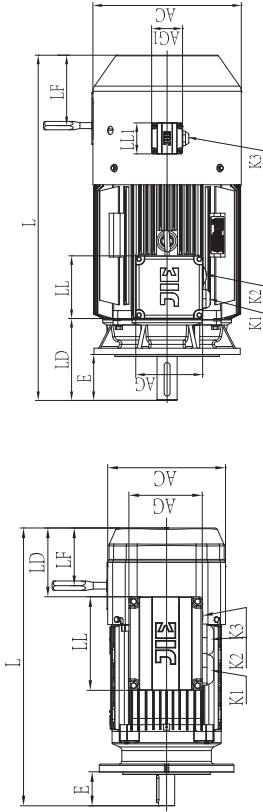

机座号/Frame Size: 63-132

机座号/Frame Size: 160-315

机座号 Frame Size JD.63.-315.	外形及安装尺寸/Overall and mounting dimensions(mm)												
	E	LL	LD	LL1	AG1	AG	AC	L	L	K1	K2	K3	
63S4	23	128	63	/	/	92	120	278	59	M20×1.5	M20×1.5	M16×1.5	
63M4													
71S4	30	139	75	/	/	109	135	315	60	M25×1.5	M25×1.5	M16×1.5	
71M4													
80S4	40	139	91	/	/	109	156	394	73	M25×1.5	M25×1.5	M16×1.5	
80M4													
90S4	50	139	102	/	/	109	177.5	413	80	M25×1.5	M25×1.5	M16×1.5	
90L4	50	139	102	/	/	109	177.5	473	80	M25×1.5	M25×1.5	M16×1.5	
100S4	60	139	102	/	/	109	198	485	74	M32×1.5	M32×1.5	M16×1.5	
100L4													
112M4	60	139	139	/	/	109	221	540	103	M32×1.5	M32×1.5	M16×1.5	
132S4	80	139	139	/	/	109	221	610	103	M32×1.5	M32×1.5	M16×1.5	
132M4													
132L4	80	182	168	/	/	152	263	662	115	M40×1.5	M40×1.5	2-M16×1.5	
160M4	110	152	180	74	74	162	314	729	150	M40×1.5	M40×1.5	M16×1.5	
160L4	110	152	180	74	74	162	314	773	150	M40×1.5	M40×1.5	M16×1.5	
180M4	110	150	196	74	74	160	355	826	180	M36×2	M36×2	M16×1.5	
180L4	110	150	196	74	74	160	355	874	180	M36×2	M36×2	M16×1.5	
200L4	110	188	202	74	74	208	397	902	200	M48×2	M48×2	M16×1.5	
225S4	140	188	232	74	74	208	446	955	220	M48×2	M48×2	M16×1.5	
225M4	140	188	232	74	74	208	446	980	220	M48×2	M48×2	M16×1.5	
250M4	140	218	246	74	74	248	485	1060	255	M63×1.5	M63×1.5	M16×1.5	
280S4	140	218	246	74	74	248	547	1134	290	M63×1.5	M63×1.5	M16×1.5	
280M4	140	218	246	74	74	248	547	1185	290	M63×1.5	M63×1.5	M16×1.5	
315S4	170	280	257	74	74	320	620	1400	320	M63×1.5	M63×1.5	M16×1.5	
315M4	170	280	257	74	74	320	620	1504	320	M63×1.5	M63×1.5	M16×1.5	
315L4	170	280	257	74	74	320	620	1504	320	M63×1.5	M63×1.5	M16×1.5	
315H4	170	280	257	74	74	320	620	1504	320	M63×1.5	M63×1.5	M16×1.5	

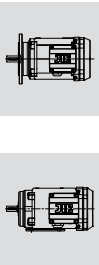



### 附录G (规范性附录) Appendix G (normative appendix)

变频带制动的电动机 Variable frequency motor with brake

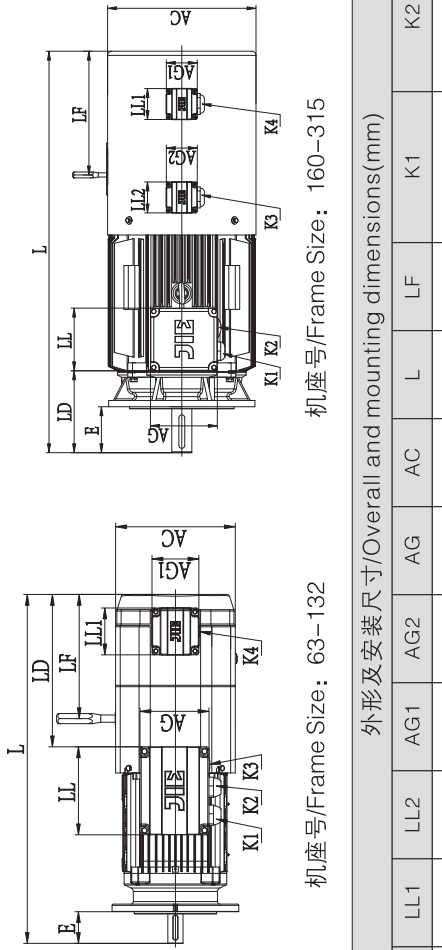

机座号/Frame Size: 160-315

机座号/Frame Size: 63-132

机座号 Frame Size JD.63.-315..		外形及安装尺寸/Overall and mounting dimensions(mm)															
E	LL	LD	LL1	LL2	AG1	AG2	AG	AC	L	LF	K1	K2	K3	K4			
23	128	141	74	74	74	74	92	120	356	137	M20×1.5	M20×1.5	M16×1.5	M20×1.5			
30	139	132	74	74	74	74	109	135	372	117	M25×1.5	M25×1.5	M16×1.5	M20×1.5			
40	139	147	74	74	74	74	109	156	450	129	M25×1.5	M25×1.5	M16×1.5	M20×1.5			
50	139	151	74	74	74	74	109	177.5	461	134	M25×1.5	M25×1.5	M16×1.5	M20×1.5			
50	139	151	74	74	74	74	109	177.5	524	134	M25×1.5	M25×1.5	M16×1.5	M20×1.5			
60	139	151	74	74	74	74	109	198	549	122	M32×1.5	M32×1.5	M16×1.5	M20×1.5			
60	139	197	74	74	74	74	109	221	598	169	M32×1.5	M32×1.5	M16×1.5	M20×1.5			
80	139	197	74	74	74	74	109	221	668	169	M32×1.5	M32×1.5	M16×1.5	M20×1.5			
80	182	247	74	74	74	74	152	263	750	195	M40×1.5	M40×1.5	M16×1.5	M20×1.5			
110	152	180	74	74	74	74	162	314	763	184	M40×1.5	M40×1.5	M16×1.5	M20×1.5			
110	152	180	74	74	74	74	162	314	807	184	M40×1.5	M40×1.5	M16×1.5	M20×1.5			
110	150	196	74	74	74	74	160	355	861	215	M36×2	M36×2	M16×1.5	M20×1.5			
110	150	196	74	74	74	74	160	355	909	215	M36×2	M36×2	M16×1.5	M20×1.5			
110	188	202	74	74	74	74	208	397	950	248	M48×2	M48×2	M16×1.5	M20×1.5			
140	188	232	74	74	74	74	208	446	1014	279	M48×2	M48×2	M16×1.5	M20×1.5			
140	188	232	74	74	74	74	208	446	1039	279	M48×2	M48×2	M16×1.5	M20×1.5			
140	218	246	74	74	74	74	248	485	1125	320	M63×1.5	M63×1.5	M16×1.5	M20×1.5			
140	218	246	74	74	74	74	248	547	1209	365	M63×1.5	M63×1.5	M16×1.5	M20×1.5			
140	218	246	74	74	74	74	248	547	1260	365	M63×1.5	M63×1.5	M16×1.5	M20×1.5			
170	280	257	74	74	74	74	320	620	1490	410	M63×1.5	M63×1.5	M16×1.5	M20×1.5			
170	280	257	74	74	74	74	320	620	1594	410	M63×1.5	M63×1.5	M16×1.5	M20×1.5			
170	280	257	74	74	74	74	320	620	1594	410	M63×1.5	M63×1.5	M16×1.5	M20×1.5			
170	280	257	74	74	74	74	320	620	1594	410	M63×1.5	M63×1.5	M16×1.5	M20×1.5			

杰牌智能传动方案提供商

# JIE INTELLIGENT DRIVE SOLUTIONS PROVIDER



**JIE**  
JDRIVE

杭州杰牌传动科技有限公司  
HANG ZHOU JIE DRIVE TECHNOLOGY CO.,LTD.

地址 Add: 中国杭州萧山·杭州空港经济区·杰牌路1号 邮编: 311223  
No.1, JIE Road, Hangzhou Airport Economic Zone, Xiaoshan,  
311223, Hangzhou, P.R. China

热线 Tel: +86 571 8299 1111 400 114 1111

总机 Call Center: +86 571 8299 2222

传真 Fax: +86 571 8299 3333

邮箱 E-mail: [jie@jie.com.cn](mailto:jie@jie.com.cn)

网址 Web: [www.jie.com.cn](http://www.jie.com.cn) [www.jiedrive.com](http://www.jiedrive.com)

**JIE USA, INC.**

Add : 493 Mission St. Carol Stream IL 60188 USA

Tel : +1 630 580 9986

E-mail: [info@jie-drives.com](mailto:info@jie-drives.com)

Web : [www.jie-drives.com](http://www.jie-drives.com)



<p><b>JRT 齿轮减速电机</b></p>	 <p><b>JRTR</b> 齿轮减速电机 规格: 19~189 传动比: 3.37~289.74 输入功率: 0.12~250 kW 输出扭矩: 2.4~56494 N.m</p>	 <p><b>JRTF</b> 平行轴-齿轮减速电机 规格: 39~169 传动比: 3.77~281.71 输入功率: 0.12~250kW 输出扭矩: 3.5~37125N.m</p>	 <p><b>JRTK</b> 锥齿轮-齿轮减速电机 规格: 39~189 传动比: 3.98~197.37 输入功率: 0.12~200kW 输出扭矩: 10~62800N.m</p>	 <p><b>JRTS</b> 蜗杆副-齿轮减速电机 规格: 39~99 传动比: 6.8~288 输入功率: 0.12~22kW 输出扭矩: 10~4900N.m</p>	 <p><b>JRTJ, JRTV</b> 齿轮减速电机 规格: 18~60 传动比: 3~1800 输入功率: 0.1~7.5kW 输出扭矩: 1.6~3292N.m</p>
<p><b>JRH 工业齿轮箱</b></p>	 <p><b>JRHH</b> 平行轴齿轮箱 规格: 3~28 传动比: 1.25~450 输入功率: 4.3~10515kW 输出扭矩: 2300~1400000N.m</p>	 <p><b>JRHB</b> 直交轴齿轮箱 规格: 4~28 传动比: 5~400 输入功率: 2.8~4908kW 输出扭矩: 5500~1400000N.m</p>	 <p><b>JRHD</b> 斗提机齿轮箱 规格: 5~16 传动比: 25~71 输入功率: 16~1305kW 输出扭矩: 11000~173000N.m</p>	 <p><b>JRHO</b> 棕桐油齿轮箱 规格: 310 传动比: 56、80 输入功率: 106、141kW 输出扭矩: 75000N.m</p>	 <p><b>JRHA</b> 空冷岛齿轮箱 规格: 166 传动比: 14 输入功率: 228kW 输出扭矩: 21000N.m</p>
<p><b>JRP 行星齿轮箱</b></p>	 <p><b>JRP</b> 大型行星齿轮箱 规格: 9~36 传动比: 25~4000 输入功率: 0.4~12934kW 输出扭矩: 22000~2600000N.m</p>	 <p><b>JRP</b> 小型行星齿轮箱 规格: 01~8 传动比: 3.08~3460 输入功率: 0.02~192kW 输出扭矩: 1000~13000N.m</p>	 <p><b>JRPH</b> 回行星行星齿轮箱 规格: 08~100 传动比: 3.4~2000 输入功率: 75~250kW 输出扭矩: 8000~100000N.m</p>	 <p><b>VR</b> 同心轴行星减速机 速比: 3~100 背隙: 1~3/3~5/5~7/3arc-min 扭矩: 6~3300N.m</p>	 <p><b>EV</b> 直角轴行星减速机 速比: 3~100 背隙: 4~9/6~11arc-min 扭矩: 12~1920N.m</p>
<p><b>JRW 蜗杆减速机</b></p>	 <p><b>JRWD</b> 蜗杆减速机 规格: 25~150 传动比: 7.5~100 输入功率: 0.06~15kW 输出扭矩: 2.6~1760N.m</p>	 <p><b>JRWND</b> NEMA蜗杆减速机 规格: 30~150 传动比: 7.5~100 输入功率: 0.06~15kW 输出扭矩: 2.6~1760N.m</p>	 <p><b>JRK, JRKB</b> 准双曲面齿轮减速机 规格: 28~68 传动比: 7.5~300 输入功率: 0.07~11.1kW 输出扭矩: 12~886N.m</p>	 <p><b>WPA</b> 蜗杆减速机 规格: 40~250 传动比: 10~60 输入功率: 0.12~33.2kW 输出扭矩: 19~2745N.m</p>	 <p><b>WPW</b> 蜗杆减速机 规格: 40~250 传动比: 10~60 输入功率: 0.12~33.2kW 输出扭矩: 6~3025N.m</p>
<p><b>JD 电动机</b></p>	 <p><b>JD-IEC</b> IEC电机 规格: 63~315 功率: 0.12~200kW 能效: IE3、IE4 (0.75~200kW)</p>	 <p><b>JD-P</b> 配减电机 规格: 63~315 功率: 0.12~200kW 能效: IE3、IE4 (0.75~200kW)</p>	 <p><b>JD-NEMA</b> NEMA电机 规格: 63~180 功率: 0.12~22kW 能效: IE3、IE4</p>	 <p><b>JD-B</b> 防爆电机 规格: 80~315 功率: 0.75~200kW 防爆等级: Exib II BT4 能效: IE3</p>	 <p><b>JDC, JCS</b> 伺服电机 伺服驱动器 功率: 0.4~7.5kW 输出扭矩: 1.27~48N.m 供电: 1AC220V / 3AC380V 通讯: 脉冲、EtherCAT、Profinet</p>
<p><b>JC 智能传动方案</b></p>	 <p><b>JC</b> 智能传动方案 减速机+电动机+变频器+传感器+物联网</p>	 <p><b>JCI</b> 智能监测系统 监测项目: 振动、转速、温度、湿度、气压、电压、电流、地理位置等</p>	 <p><b>JCMB</b> 变频一体减速机 规格: 004~0075 功率: 0.37~7.5kW 防护等级: IP54~IP65 供电: 3AC 380~440V 输出频率: 0~200Hz</p>	 <p><b>JCME</b> 分布式变频器 功率: 0.75~5.5kW 通讯接口: ModbusRTU Profinet</p>	 <p><b>JCF</b> 变频器 规格: 0075~0550 功率: 0.75~55kW 输出频率: 0~200Hz 载波频率: 8~32KHz</p>
<p><b>其它减速机</b></p>	 <p><b>JRESR</b> 不锈钢齿轮减速机 规格: 37~67 传动比: 3.41~199.81 输入功率: 0.18~7.5kW 输出扭矩: 26~670N.m</p>	 <p><b>JRESK</b> 锥齿轮-不锈钢齿轮减速机 规格: 37~67 传动比: 3.98~145.14 输入功率: 0.18~5.5kW 输出扭矩: 12~910N.m</p>	 <p><b>JRESS</b> 不锈钢蜗杆减速机 规格: 40~90 传动比: 7.5~100 输入功率: 0.09~4kW 输出扭矩: 19~458N.m</p>	 <p><b>JRSS</b> 丝杆升降机 规格: 35~150 传动比: 5~40 输入功率: 0.19~16.3kW 起升力: 500~26050kg</p>	 <p><b>JRTM</b> 锥齿轮转向器 规格: 2~25 传动比: 1~5 输入功率: 0.014~335kW 输入转速: 10~1450r/min</p>
<p><b>JRGC 工程分动箱</b></p>	 <p><b>JRGC</b> 工程分动箱 规格: 0401、1501 传动比: 0.589、0.659、0.756、0.825 输出最大扭矩: 1390N.m 行走最大扭矩: 40000N.m</p>	 <p><b>JTA</b> 轴装式减速机 规格: 80/90~100/120 速比: 5~31.5 功率: 11~45KW 扭矩: 6600~105000N.m</p>	 <p><b>JEC</b> 扶梯主机 规格: 2~15、2~25 传动比: 24.5 效率: ≥96% 使用寿命: 146000h 输出扭矩: 3530~5150N.m</p>	 <p><b>JN</b> 农机齿轮箱 传动比: 0.364~2.33 输入转速: 800r/min 效率: ≥96%</p>	 <p>杰牌智能传动方案提供商 更多产品敬请咨询</p> <p>JIE Drive Product Catalogue</p>



# 杰牌智能传动工业园

JIE Intelligent Drive Industrial Zone

办公区: A座商务中心、B座创新中心、C座运营中心; 生产区: 1号工厂、2号工厂、3号工厂、万杰工厂、5号工厂; 生活区: 杰牌楼、匠心楼、精益楼

Office Area: Building A Business Center, Building B Innovation Center, Building C Operation Center, Production Area: No.1 Plant, No.2 Plant, No. 3 Plant, Wanjie Plant, No. 5 Plant, Living Area: JIE Building, Artisans Building, Lean Building.



# 杰牌智能传动方案提供商

JIE Intelligent Drive Solutions Provider

JRT 齿轮减速机 JRH 工业齿轮箱 JRP 行星齿轮箱 JRW 蜗杆减速机 JD 电动机 JC 智能传动方案  
减速机 + 电动机 + 变频器 + 传感器 + 物联网  
大数据 云计算 物联网 AI技术 智能化

JRT Gearmotor JRH Industrial Gear Units JRP Planetary Gear Units JRW Worm Gears JD Motors JC Intelligent Drive Solutions Gear units + Motors + Inverters + Sensors + Internet of Things  
Big Data Cloud Computing Internet of Things Artificial Intelligence Intelligence



# 杰牌未来工厂

JIE Future Factory

杰牌未来工厂“12345”规划: 1个方案—杰牌智能传动方案提供商; 2个平台—线下杰牌智能传动产业平台、线上杰牌新制造平台; 3个区块—办公区、生产区、生活区; 4个标准—中国标准、美国标准、德国标准、日本标准; 5个智能—智能工厂、智能产品、智能服务、智能体验、智能人才。我们致力于打造“环境友好型、发展持续型、服务全球型”的专业化杰牌、智能化杰牌、全球化杰牌。

“12345” Plan of JIE Future Factory: 1 Solution, i.e. JIE Intelligent Drive Solutions Provider; 2 Platforms, i.e. Off-line JIE Intelligent Drive Industrial Platform and On-line JIE New Manufacturing Platform; 3 Areas, i.e. Office Area, Production Area and Living Area; 4 Standards, i.e. Chinese Standard, American Standard, German Standard and Japanese Standard; 5 Intelligence, i.e. Intelligent Plants, Intelligent Products, Intelligent Services, Intelligent Experiences and Intelligent Talents. We are dedicated to build a professional, Intelligent and Global JIE on Environment-friendly, sustainable development, global service basis.

## 办公区 Office Area



## 生产区 Production Area



## 生活区 Living Area

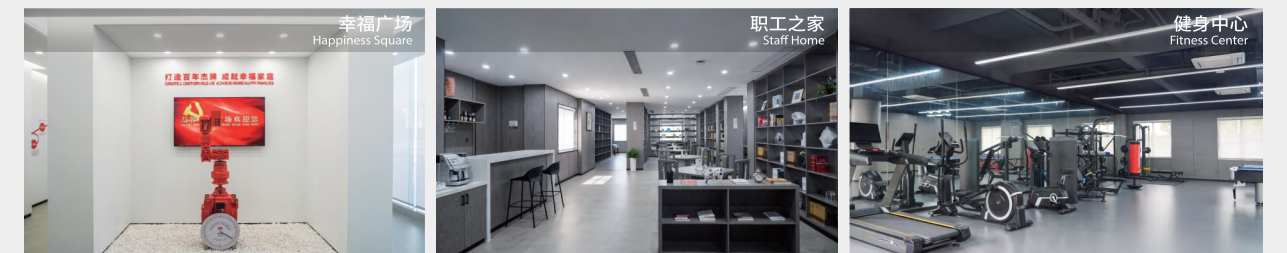



## 杰牌智能传动平台产品

Platform Products of JIE Intelligent Drive

产品标准化实现平台化,工艺标准化实现自动化,流程标准化实现信息化。

Standardizing the products to realize platformization, Standardizing the technologies to realize automation, Standardizing the processes to realize informatization.



## 杰牌智能传动项目

JIE Intelligent Drive Project

智能工厂+智能产品+智能服务,推进精益生产,建设智能工厂,构建产业联盟 实现合作共赢。

Intelligent Plants + Intelligent Products + Intelligent Services, to promote lean production and build intelligent plants, and to build industrial alliances and achieve win-win cooperation.



## 杰牌智能传动项目应用案例

An application case of JIE Intelligent Drive Solutions

智能计划物流,箱体智能工厂,齿轮智能工厂,电机智能工厂,装配智能工厂,智能检测试验等项目传动方案。  
Projects Drive Solutions incl. Intelligent Planning Logistics, Intelligent Plant of Gear Housing, Intelligent Plant of Gears, Intelligent Plant of Motors, Intelligent Plant of Assembly, Intelligent Tests, etc.

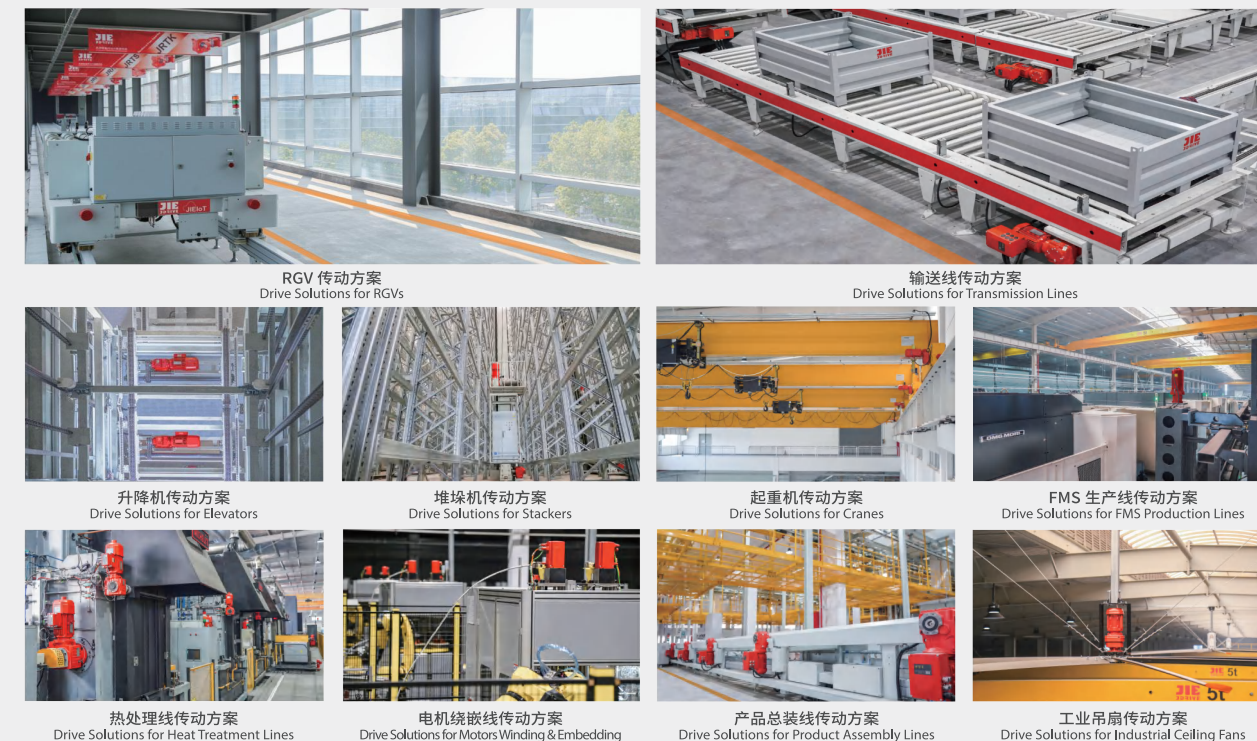

## 杰牌智能传动行业应用案例

Industrial application cases of JIE Intelligent Drive Solutions

杰牌新衣食住行源运等行业传动方案。

JIE Industrial Drive Solutions for New Manufacturing, Clothing, Food, Residence, Trips, Energy, Transportation, etc.





## 在专业化的路上走向胜利 On road to specialization strive together

陈 杰 词  
Lyric: Chen Jie  
钱建隆 曲  
Music: Qian Jian Long

1 =  $^bE$   $\frac{4}{4}$

稍快、朝气蓬勃地  
allegretto, full of youth

||: (  $\overset{3}{111}$   $\overset{3}{111}$   $\overset{3}{111}$  1 |  $\overset{3}{111}$   $\overset{3}{111}$   $\overset{3}{111}$  1 |  $\underline{5.1123456}$  |  $\overset{3}{5} \underline{5.5.5} 1 0$  ) |

$\underline{5.1}$   $\underline{1.2}$   $\underline{3.1}$  0 |  $\underline{5.4}$   $\underline{3.2}$   $\underline{3.1}$  0 |  $i \cdot \underline{7}$   $\underline{7}$   $\underline{6}$   $\underline{6}$  5 |  $\underline{6.5}$   $\underline{3.4}$  5 - |

要做 就做 一流 是我 永恒 追求 产业 联盟 我们 一起走  
To be the star is my eternal pursue industrial union we walk together  
产业 事业 家业 共同 富裕 和谐 目标 在前 我们 一起走  
Estate career family harmonious with wealth for the goal ahead we walk together

$\underline{5.1}$   $\underline{1.2}$   $\underline{3.1}$  0 |  $\underline{5.4}$   $\underline{3.2}$   $\underline{3.1}$  0 |  $\bar{1}$   $\bar{1}$   $\bar{7}$   $\bar{6}$  |  $\underline{5.4}$   $\underline{3.4}$  2 $\vee$ 1 |

聚 万物 之灵 造 天地 之杰 产业 发展 我们 一起走 啦  
Nimbus from all beings making it outstanding industry developing we walk together La  
团结 创新 专业 推动 联盟 发展 胜利 在前 我们 一起走 啦  
Join Innovation Expertise enhancing the union for the victory ahead we walk together La

$i$  -  $i$   $i$   $\underline{7}$   $i$  | 5 - - 1 | 6 -  $\underline{6.6}$   $\underline{7}$   $i$  3 - - - |  
啦 啦啦 啦啦 啦啦 啦啦 啦啦 啦啦 啦啦  
La La La La La La La La La La

(节奏强烈、有冲击力)  
(hot, powerful)

1 - 4 5 |  $\underline{6.7}$   $i$  6 · 5 | 6 6  $\underline{5.4}$   $\underline{3.5}$  | 5 - - - |

在 专业 化的 路 上 我们 一起 努力  
On road to specialization we strive together

1 - 4 5 |  $\underline{6.7}$   $i$  6 · 5 | 4 3  $\underline{2.2}$   $\underline{1.2}$  | 2 - - - |

在 专业 化的 路 上 我们 走向 胜利  
On road to specialization we go to victory

1 - 4 5 |  $\underline{6.7}$   $i$  6 · 5 | 6 6  $\underline{5.4}$   $\underline{3.6}$  | 6 - - - |

在 专业 化的 路 上 我们 一起 努力  
On road to specialization we strive together

1 - 4 5 |  $\underline{6.7}$   $i$  6 · 5 |  $\overset{1}{4}$  3  $\underline{2.2}$   $\underline{3.1}$  | 1 - - - ||

在 专业 化的 路 上 我们 走向 胜利  
On road to specialization we go to victory

- 2  $\underline{4}$  3  $\underline{2.2}$   $\underline{3.1}$  | 1 0 0  $\overset{>}{i}$  |  $\overset{>}{i}$  - 0 0 | 0 0 0 0 ||

我 们 走 向 胜 利 胜 利  
we go to victory Victory